

# Washer-Extractors

Pocket Hardmount

Design 5

Refer to Page 9 for Model Identification



Installation/Operation/Maintenance

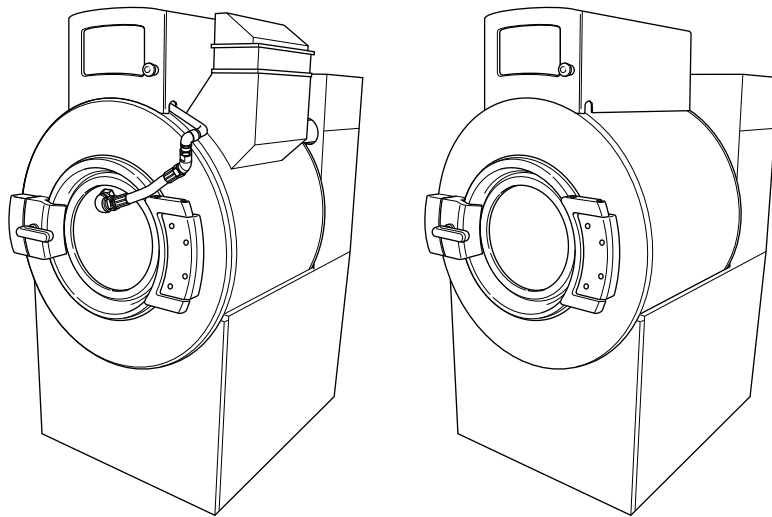

PHM1430C\_SVG

## Original Instructions

Keep These Instructions for Future Reference.

**CAUTION: Read the instructions before using the machine.**

(If this machine changes ownership, this manual must accompany machine.)

**Alliance**<sup>TM</sup>  
Laundry Systems

[www.alliancelaundry.com](http://www.alliancelaundry.com)

F8620601ENR4  
July 2018



# Table of Contents

<b>Models with Wireless Board Installed.....</b>	<b>5</b>
<b>Safety Information.....</b>	<b>6</b>
Explanation of Safety Messages.....	6
Important Safety Instructions.....	6
Safety Decals.....	7
Operator Safety.....	8
<b>Introduction.....</b>	<b>9</b>
Model Identification.....	9
Delivery Inspection.....	9
Serial Plate Location.....	10
Replacement Parts .....	10
Customer Service.....	10
Manufacturing Date.....	10
<b>Specifications and Dimensions.....</b>	<b>11</b>
Machine Dimensions .....	14
Mounting Bolt Hole Locations - 45 and 65 Pound Models.....	20
Mounting Bolt Hole Locations - 85 and 105 Pound Models.....	22
Mounting Bolt Hole Locations - 130-200 Pound Models.....	24
<b>Installation.....</b>	<b>26</b>
Foundation Options.....	26
Machine Installation on Existing Floor.....	26
Elevated Pad Installation on Existing Floor.....	26
New Foundation.....	26
Isolated Pad Installation.....	26
Foundation and Pad Installation.....	26
Floor Layout and Pad Dimensions.....	28
Foundation Requirements.....	32
Machine Mounting and Grouting.....	38
Mounting Bolt Pattern.....	42
Floor Load Data.....	43
Drain Connection Requirements.....	44
Water Connection Requirements.....	46
Connect Inlet Hoses .....	48
Connect Inlet Hoses with Y-Connectors.....	48
Plumbing Diagrams.....	50
Electrical Installation Requirements.....	53
Input Power Conditioning.....	54
Input Voltage Requirements.....	54

© Copyright 2018, Alliance Laundry Systems LLC

All rights reserved. No part of the contents of this book may be reproduced or transmitted in any form or by any means without the expressed written consent of the publisher.

Circuit Breakers and Quick Disconnects.....	54
Connection Specifications.....	54
Single-Phase Connections.....	55
Three-Phase Connections.....	56
Grounding.....	56
Phase Adder.....	57
Thermal Overload Protector.....	57
North American Approval.....	57
CE Approval.....	64
Steam Requirements (Steam Heat Option Only).....	69
Chemical Injection Supply System.....	70
Five Compartment Supply Dispenser (Optional).....	74
External Supplies.....	75
Chemical Injection Using Internal 24VAC Control Transformer.....	76
Chemical Injection Using External AC Power Source.....	76
External Supply Signals.....	77
<b>Start Up.....</b>	<b>79</b>
Basket Rotation.....	79
Safety Stability Switch Operation.....	79
<b>Operation.....</b>	<b>80</b>
Operating Instructions.....	80
Control Instructions.....	82
Models with N Control.....	82
Models with D Control.....	82
Emergency Stop Button.....	82
Shakeout Routine.....	83
Basket Jog Feature (160 and 200 Pound Models Only).....	83
<b>Maintenance.....</b>	<b>84</b>
Daily.....	84
Beginning of Day.....	84
End of Day.....	84
Monthly.....	85
Yearly.....	86
Care of Stainless Steel.....	87
<b>Disposal of Unit.....</b>	<b>89</b>
<b>China Restriction of hazardous substances (RoHS).....</b>	<b>90</b>

# Models with Wireless Board Installed

This device is granted for use in Mobile only configurations in which the antennas used for this transmitter must be installed to provide a separation distance of at least 20cm from all person and not be co-located with any other transmitters except in accordance with FCC and Industry Canada multi-transmitter product procedures.





# Safety Information

## Explanation of Safety Messages

Precautionary statements (“DANGER,” “WARNING,” and “CAUTION”), followed by specific instructions, are found in this manual and on machine decals. These precautions are intended for the personal safety of the operator, user, servicer, and those maintaining the machine.

	<b>DANGER</b>
Indicates an imminently hazardous situation that, if not avoided, will cause severe personal injury or death.	

	<b>WARNING</b>
Indicates a hazardous situation that, if not avoided, could cause severe personal injury or death.	

	<b>CAUTION</b>
Indicates a hazardous situation that, if not avoided, may cause minor or moderate personal injury or property damage.	

Additional precautionary statements (“IMPORTANT” and “NOTE”) are followed by specific instructions.

**IMPORTANT:** The word “IMPORTANT” is used to inform the reader of specific procedures where minor machine damage will occur if the procedure is not followed.

**NOTE:** The word “NOTE” is used to communicate installation, operation, maintenance or servicing information that is important but not hazard related.

## Important Safety Instructions

	<b>WARNING</b>
To reduce the risk of fire, electric shock, serious injury or death to persons when using your washer, follow these basic precautions:	
W023	

- Read all instructions before using the washer.
- Install the washer according the INSTALLATION instructions. Refer to the EARTH/GROUND instructions in the IN-

STALLATION manual for the proper earth/ground connection of the washer. All connections for water, drain, electrical power and earth/ground must comply with local codes and be made by licensed personnel when required. It is recommended that the machine be installed by qualified technicians.

- Do not install or store the washer where it will be exposed to water and/or weather.
- To prevent fire and explosion, keep the area around machine free from flammable and combustible products. Do not add the following substances or textiles containing traces of the following substances to the wash water: gasoline, kerosene, waxes, cooking oils, vegetable oils, machine oils, dry-cleaning solvents, flammable chemicals, thinners, or other flammable or explosive substances. These substances give off vapors that could ignite, explode or cause the fabric to catch fire by itself.
- Under certain conditions, hydrogen gas may be produced in a hot water system that has not been used for two weeks or more. HYDROGEN GAS IS EXPLOSIVE. If the hot water system has not been used for such a period, before using a washing machine or combination washer-dryer, turn on all hot water faucets and let the water flow from each for several minutes. This will release any accumulated hydrogen gas. The gas is flammable, do not smoke or use an open flame during this time.
- To reduce the risk of an electric shock or fire, DO NOT use an extension cord or an adapter to connect the washer to the electrical power source.
- Do not allow children to play on or in the washer. Close supervision of children is necessary when the washer is used near children. This appliance is not intended for use by young children or infirm persons without supervision. Young children should be supervised to ensure that they do not play with the appliance. This is a safety rule for all appliances.
- DO NOT reach and/or climb into the tub or onto the washer, ESPECIALLY if the wash drum is moving. This is an imminently hazardous situation that, if not avoided, will cause severe personal injury or death.
- Never operate the washer with any guards, panels and/or parts removed or broken. DO NOT bypass any safety devices or tamper with the controls.
- Use washer only for its intended purpose, washing textiles. Never wash machine parts or automotive parts in the machine. This could result in serious damage to the basket or tub.
- Use only low-sudsing, no-foaming types of commercial detergent. Be aware that hazardous chemicals may be present. Wear hand and eye protection when adding detergents and chemicals. Always read and follow manufacturer’s instructions on packages of laundry and cleaning aids. Heed all warnings or precautions. To reduce the risk of poisoning or

chemical burns, keep them out of the reach of children at all times [preferably in a locked cabinet].

- Do not use fabric softeners or products to eliminate static unless recommended by the manufacturer of the fabric softener or product.
- Always follow the fabric care instructions supplied by the textile manufacturer.
- Loading door **MUST BE CLOSED** any time the washer is to fill, tumble or spin. **DO NOT** bypass the loading door switch by permitting the washer to operate with the loading door open. Do not attempt to open the door until the washer has drained and all moving parts have stopped.
- Do not attach anything to the supply dispenser's nozzles, if applicable. The air gap must be maintained.
- Do not operate the machine without the water reuse plug or water reuse system in place, if applicable.
- Be sure water connections have a shut-off valve and that fill hose connections are tight. **CLOSE** the shut-off valves at the end of each wash day.
- Keep washer in good condition. Bumping or dropping the washer can damage safety features. If this occurs, have washer checked by a qualified service person.
- **DANGER:** Before inspecting or servicing machine, power supply must be turned **OFF**. The servicer needs to wait for at least 5 minutes after turning the power **OFF** and needs to check for residual voltage with a voltage meter. The inverter capacitor or EMC filter remains charged with high voltage for some time after powering **OFF**. This is an imminently hazardous situation that, if not avoided, will cause severe personal injury or death.
- Do not repair or replace any part of the washer, or attempt any servicing unless specifically recommended in the user-maintenance instructions or in published user-repair instructions that the user understands and has the skills to carry out. **ALWAYS** disconnect the washer from electrical, power and water supplies before attempting any service.
- Disconnect the power by turning off the circuit breaker or by unplugging the machine. Replace worn power cords.
- Before the washer is removed from service or discarded, remove the door to the washing compartment.
- Failure to install, maintain, and/or operate this washer according to the manufacturer's instructions may result in conditions which can produce bodily injury and/or property damage.

**NOTE: The WARNINGS and IMPORTANT SAFETY INSTRUCTIONS appearing in this manual are not meant to cover all possible conditions and situations that may occur. Common sense, caution and care must be exercised when installing, maintaining, or operating the washer.**

Any problems or conditions not understood should be reported to the dealer, distributor, service agent or the manufacturer.



## WARNING

**Machine installations must comply with minimum specifications and requirements stated in the applicable Installation Manual, any applicable municipal building codes, water supply requirements, electrical wiring regulations and any other relevant statutory regulations. Due to varied requirements and applicable local codes, this machine must be installed, adjusted, and serviced by qualified maintenance personnel familiar with applicable local codes and the construction and operation of this type of machinery. They must also be familiar with the potential hazards involved. Failure to observe this warning may result in personal injury, property damage, and/or equipment damage, and will void the warranty.**

W820

**IMPORTANT: Ensure that the machine is installed on a level floor of sufficient strength. Ensure that the recommended clearances for inspection and maintenance are provided. Never allow the inspection and maintenance space to be blocked.**



## WARNING

**Never touch internal or external steam pipes, connections, or components. These surfaces can be extremely hot and will cause severe burns. The steam must be turned off and the pipe, connections, and components allowed to cool before the pipe can be touched.**

SW014



## WARNING

**Install the machine on a level floor of sufficient strength. Failure to do so may result in conditions which can produce serious injury, death and/or property damage.**

W703

**NOTE: All appliances are produced according the EMC-directive (Electro-Magnetic-Compatibility). They can be used in restricted surroundings only (comply minimally with class A requirements). For safety reasons there must be kept the necessary precaution distances with sensitive electrical or electronic device(s). These machines are not intended for domestic use by private consumers in the home environment.**

## Safety Decals

Safety decals appear at crucial locations on the machine. Failure to maintain legible safety decals could result in injury to the operator or service technician.

Use manufacturer-authorized spare parts to avoid safety hazards.

## Operator Safety

	<b>WARNING</b>
<b>NEVER insert hands or objects into basket until it has completely stopped. Doing so could result in serious injury.</b>	
SW012	

Machines referred to by model in this manual are intended to be used by the general public in applications such as:

- staff areas in shops, offices, kitchens and other working environments
- by clients in hotels, motels and other residential type environments
- areas for communal use in blocks of flats or in launderettes
- any other similar applications

Installation of these machines must fully conform to the instructions contained in this manual.

The following maintenance checks must be performed daily:

1. Verify that all warning labels are present and legible, replace as necessary.
2. Check door interlock before starting operation of the machine:
  - a. Attempt to start the machine with the door open. The machine should not start.
  - b. Close the door without locking it and start the machine. The machine should not start.
  - c. Attempt to open the door while a cycle is in progress. The door should not open.

If the door lock and interlock are not functioning properly, disconnect power and call a service technician.

3. Do not attempt to operate the machine if any of the following conditions are present:
  - a. The door does not remain securely locked during the entire cycle.
  - b. Excessively high water level is evident.
  - c. Machine is not connected to a properly grounded circuit.

Do not bypass any safety devices in the machine.

	<b>WARNING</b>
<b>Operating the machine with severe out-of-balance loads could result in personal injury and serious equipment damage.</b>	
W728	



# Introduction

## Model Identification

Information in this manual is applicable to these models:

<b>45 Pound [20.4 Kg] Models</b>					
UWG045D3	UWH045D3	UWJ045D3	UWK045D3	UWT045D3	UWU045D3
UWG045D4	UWH045D4	UWJ045D4	UWK045D4	UWT045D4	UWU045D4
UWG045N1	UWH045N1	UWJ045N1	UWK045N1	UWT045N1	UWU045N1
UWG045N2	UWH045N2	UWJ045N2	UWK045N2	UWT045N2	UWU045N2
<b>65 Pound [29.5 Kg] Models</b>					
UWG065D3	UWH065D3	UWJ065D3	UWK065D3	UWT065D3	UWU065D3
UWG065D4	UWH065D4	UWJ065D4	UWK065D4	UWT065D4	UWU065D4
UWG065N1	UWH065N1	UWJ065N1	UWK065N1	UWT065N1	UWU065N1
UWG065N2	UWH065N2	UWJ065N2	UWK065N2	UWT065N2	UWU065N2
<b>85 Pound [38.6 Kg] Models</b>					
UWG085D3	UWH085D3	UWJ085D3	UWK085D3	UWT085D3	UWU085D3
UWG085D4	UWH085D4	UWJ085D4	UWK085D4	UWT085D4	UWU085D4
UWG085N1	UWH085N1	UWJ085N1	UWK085N1	UWT085N1	UWU085N1
UWG085N2	UWH085N2	UWJ085N2	UWK085N2	UWT085N2	UWU085N2
<b>105 Pound [47.6 Kg] Models</b>					
UWG105D3	UWH105D3	UWJ105D3	UWK105D3	UWT105D3	UWU105D3
UWG105D4	UWH105D4	UWJ105D4	UWK105D4	UWT105D4	UWU105D4
UWG105N1	UWH105N1	UWJ105N1	UWK105N1	UWT105N1	UWU105N1
UWG105N2	UWH105N2	UWJ105N2	UWK105N2	UWT105N2	UWU105N2
<b>130 Pound [59 Kg] Models</b>					
UWG130D3	UWH130D3	UWJ130D3	UWK130D3	UWT130D3	UWU130D3
UWG130D4	UWH130D4	UWJ130D4	UWK130D4	UWT130D4	UWU130D4
UWG130N1	UWH130N1	UWJ130N1	UWK130N1	UWT130N1	UWU130N1
UWG130N2	UWH130N2	UWJ130N2	UWK130N2	UWT130N2	UWU130N2
<b>160 Pound [72.6 Kg] Models</b>					
UWG160D3	UWH160D3	UWJ160D3	UWK160D3	UWT160D3	UWU160D3
UWG160D4	UWH160D4	UWJ160D4	UWK160D4	UWT160D4	UWU160D4
<b>200 Pound [90.7 Kg] Models</b>					
UWG200D3	UWH200D3	UWJ200D3	UWK200D3	UWT200D3	UWU200D3
UWG200D4	UWH200D4	UWJ200D4	UWK200D4	UWT200D4	UWU200D4

## Delivery Inspection

Upon delivery, visually inspect crate, protective cover, and unit for any visible shipping damage. If signs of possible damage are evident, have the carrier note the condition on the shipping papers before the shipping receipt is signed, or advise the carrier of the condition as soon as it is discovered.

## Serial Plate Location

The serial plate is located on the rear panel and inside the door of the machine.

The serial plate is located on the rear panel and inside the door of the machine and is programmed in the control. To access the Machine ID Menu through the control:

1. Press the keypad to enter *System Menu*.
2. Scroll to highlight Diagnostics and press the keypad to enter *Diagnostics Menu*.
3. Scroll to highlight Machine ID and press the keypad to enter *Machine ID Menu*.

Always provide the machine's serial number and model number when ordering parts or when seeking technical assistance. Refer to *Figure 1*.

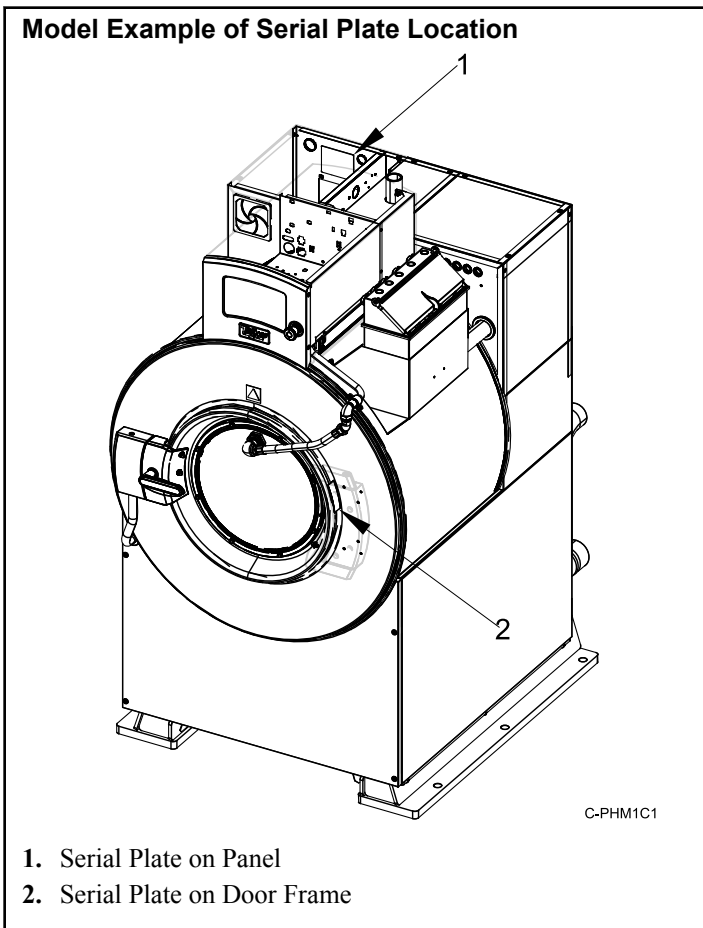

Figure 1

## Replacement Parts

If literature or replacement parts are required, contact the source from which the machine was purchased or contact Alliance Laundry Systems at +1 (920) 748-3950 for the name and address of the nearest authorized parts distributor.

## Customer Service

For technical assistance, contact your local distributor or contact:

Alliance Laundry Systems

Shepard Street

P.O. Box 990

Ripon, WI 54971-0990

U.S.A.

[www.alliancelaundry.com](http://www.alliancelaundry.com)

Phone: +1 (920) 748-3121 Ripon, Wisconsin

## Manufacturing Date

The manufacturing date for your unit can be found on the serial number. The first two digits indicate the year. The third and fourth digits indicate the month. For example, a unit with serial number 1505000001 was manufactured in May 2015.

**EAC**

# Specifications and Dimensions

Specifications	45	65	85	105	130	160	200
<b>Overall Dimensions</b>							
Overall width, in. [mm]	34.1 [867]	34.1 [867]	40.1 [1019]	40.1 [1019]	46.1 [1171]	46.1 [1171]	46.1 [1171]
Overall height, in. [mm]	64.4 [1637]	64.4 [1637]	69.1 [1755]	69.1 [1755]	76.1 [1932]	76.1 [1932]	76.1 [1171]
Overall depth, in. [mm]	45.3 [1151]	51.1 [1298]	51.2 [1300]	56.2 [1427]	54.5 [1384]	60.0 [1524]	67.5 [1715]
<b>Weight and Shipping Information</b>							
Net weight, lbs. [kg]	1080 [490]	1110 [499]	1670 [757]	1700 [771]	2040 [925]	2070 [939]	2160 [980]
Standard shipping weight, lbs. [kg]	1120 [508]	1150 [522]	1720 [780]	1750 [794]	2100 [953]	2130 [966]	2220 [1007]
Standard shipping volume, ft <sup>3</sup> [m <sup>3</sup> ]	75 [2]	75 [2]	107 [3]	107 [3]	139 [4]	139 [4]	157 [4.4]
Standard shipping dimensions (WxDxH), in. [mm]	37.2 x 53.8 x 65 [945 x 1370 x 1650]	37.2 x 53.8 x 65 [945 x 1370 x 1650]	43.2 x 61.8 x 69.4 [1097 x 1570 x 1763]	43.2 x 61.8 x 69.4 [1097 x 1570 x 1763]	49.2 x 64.8 x 76.4 [1250 x 1646 x 1941]	49.2 x 64.8 x 76.4 [1250 x 1646 x 1941]	49.2 x 72.3 x 76.4 [1250 x 1836 x 1941]
Slat crate shipping weight, lbs. [kg]	1250 [567]	1280 [581]	1870 [848]	1900 [862]	2260 [1025]	2290 [1039]	2390 [1084]
Slat crate shipping volume, ft <sup>3</sup> [m <sup>3</sup> ]	97 [3]	97 [3]	158 [4.5]	158 [4.5]	186 [5.3]	186 [5.3]	207 [5.9]
Slat crate shipping dimensions (WxDxH), in. [mm]	41.7 x 56.8 x 70.8 [1060 x 1440 x 1800]	41.7 x 56.8 x 70.8 [1060 x 1440 x 1800]	47.7 x 64.8 x 88.3 [1212 x 1646 x 2243]	47.7 x 64.8 x 88.3 [1212 x 1646 x 2243]	53.7 x 67.8 x 88.3 [1364 x 1722 x 1915]	53.7 x 67.8 x 88.3 [1364 x 1722 x 1915]	53.7 x 75.3 x 88.3 [1364 x 1913 x 2243]
<b>Wash Cylinder Information</b>							
Cylinder diameter, in. [mm]	31.0 [787]	31.0 [787]	36.0 [914]	36.0 [914]	42.0 [1067]	42.0 [1067]	42.0 [1067]
Cylinder depth, in. [mm]	16.6 [4222]	22.1 [561]	22.0 [559]	27.0 [686]	24.5 [622]	30.0 [762]	37.5 [953]
Cylinder volume, ft <sup>3</sup> [l]	7.3 [185]	9.7 [246]	13.0 [368]	15.9 [450]	19.6 [555]	24.1 [682]	30.1 [852]
Cylinder capacity, lbs. [kg]	45 [20.4]	65 [29.5]	85 [38.6]	105 [47.6]	130 [59]	160 [72.6]	200 [90.7]
Perforation size, in. [mm]	0.188 [4.8]	0.188 [4.8]	0.188 [4.8]	0.188 [4.8]	0.188 [4.8]	0.188 [4.8]	0.188 [4.8]
Perforation open area, %	21.3	21.3	23.0	23.4	27.4	27.9	27.3
<b>Door Opening Information</b>							
Door opening size, in. [mm]	17.8 [452]	17.8 [452]	21.0 [533]	21.0 [533]	24.8 [630]	24.8 [630]	24.8 [630]
Height of door bottom above floor, in. [mm]	28.8 [732]	28.8 [732]	28.8 [732]	28.8 [732]	30.5 [775]	30.5 [775]	30.5 [775]

Table 1 *continues...*

<b>Specifications</b>	<b>45</b>	<b>65</b>	<b>85</b>	<b>105</b>	<b>130</b>	<b>160</b>	<b>200</b>
<b>Power Consumption</b>							
Average power used per cycle, kW-hr. (Non-heat models)	0.30	0.35	0.45	0.52	0.64	0.75	0.80
<b>Estimated Building Heat Load</b>							
HVAC load	Use 15% of total energy used per cycle.						
<b>Drive Train Information</b>							
Number of motors in. drive train	1	1	1	1	1	1	1
Drive motor power, hp [kW]	5.0 [3.7]	5.0 [3.7]	7.5 [5.6]	7.5 [5.6]	10 [7.5]	10 [7.5]	10 [7.5]
<b>Cylinder Speeds</b>							
1/2 Wash/reverse, RPM [G]	30 [0.4]	30 [0.4]	28 [0.4]	28 [0.4]	26 [0.4]	26 [0.4]	26 [0.4]
Wash/reverse, RPM [G]	42 [0.78]	42 [0.78]	39 [0.78]	39 [0.78]	36 [0.77]	36 [0.77]	36 [0.77]
Distribution, RPM [G]	75 [2.5]	75 [2.5]	70 [2.5]	70 [2.5]	65 [2.5]	65 [2.5]	65 [2.5]
Very low extract, RPM [G]	248 [27]	248 [27]	230 [27]	230 [27]	213 [27]	213 [27]	213 [27]
Low extract, RPM [G]	477 [100] (L-Speed)*	477 [100] (L-Speed)*	443 [100]	443 [100]	410 [100]	410 [100]	366 [80]
Medium extract, RPM [G]	674 [200] (M-Speed)*	674 [200] (M-Speed)*	542 [150]	542 [150]	502 [150]	502 [150]	410 [100]
High extract, RPM [G]	754 [250]	754 [250]	626 [200] (M-Speed)*	626 [200] (M-Speed)*	579 [200] (M-Speed)*	579 [200]	458 [125]
Very high extract, RPM [G]	826 [300]	826 [300]	700 [250]	700 [250]	648 [250]	648 [250]	502 [150]
Ultra High extract, RPM [G]	954 [400] (V-Speed)*	954 [400] (V-Speed)*	766 [300] (V-Speed)*	766 [300] (V-Speed)*	710 [300] (V-Speed)*	710 [300] (V-Speed)*	579 [200] (M-Speed)*
*Maximum extract speed, depending on model. Refer to the L, M or V in the 10th digit of the model number.							
<b>Balance Detection</b>							
Stability switch installed	STD	STD	STD	STD	STD	STD	STD
<b>Direct Steam Heating (Optional)</b>							
Steam inlet connection size, in. (NPT)	1/2	1/2	1/2	1/2	3/4	3/4	3/4
Number of steam inlets	1	1	1	1	1	1	1
Maximum pressure, psi [kPa]	85 [570]	85 [570]	85 [570]	85 [570]	85 [570]	85 [570]	85 [570]
Required pressure, (min. - max. psi [kPa] )	30-85 [200-570]	30-85 [200-570]	30-85 [200-570]	30-85 [200-570]	30-85 [200-570]	30-85 [200-570]	30-85 [200-570]

Table 1 continues...

Specifications		45	65	85	105	130	160	200
Steam re- quired to raise bath temperature, 10°F, lbs. [10°C, kg]	LOW	2.5 [1.1]	3.3 [1.5]	4.6 [2.1]	5.7 [2.6]	6.7 [3.0]	8.3 [3.8]	10.4 [4.6]
	MED	2.7 [1.2]	3.7 [1.7]	5.2 [2.4]	6.5 [2.9]	7.8 [3.5]	9.5 [4.3]	11.9 [5.2]
	HIGH	3.1 [1.4]	4.1 [1.9]	6.1 [2.8]	7.6 [3.4]	9.1 [4.1]	11.1 [5.0]	13.9 [6.1]
Average consumption per cycle, BHP [kgf m]		1.6 [122]	2.1 [160]	3.1 [236]	3.8 [289]	4.6 [350]	5.8 [441]	7.25 [551]
<b>Electrical Heating (Optional)</b>								
Total electri- cal heating capacity, kW	200V	19.1	19.1	28.6	28.6	N/A	N/A	N/A
	240V	27.4	27.4	41.2	41.2	N/A	N/A	N/A
	380V	17.2	17.2	17.2	17.2	34.4	34.4	34.4
	415V	20.5	20.5	20.5	20.5	41.0	41.0	41.0
	480V	27.4	27.4	27.4	27.4	54.8	54.8	54.8
Number of electrical heat- ing elements		6/6	6/6	9/6	9/6	12	12	12
Electrical heating element size, kW		4.2	4.2	4.2	4.2	4.2	4.2	4.2
Time re- quired to raise bath temperature, minutes per 10°F [5.5°C]	LOW	1.562	1.633	1.685	1.997	1.927	2.215	2.471
	MED	1.718	1.896	1.874	2.168	2.015	2.375	2.676
	HIGH	1.739	2.239	2.095	2.471	2.272	2.675	2.860
<b>Noise Emission</b>								
dBA	Max Extract	77	77	78	78	80	80	75
	Med Extract	69	69	70	70	75	75	68
	Agitate	64	64	66	66	66	66	66
N/A = Not Applicable								

Table 1

# Machine Dimensions

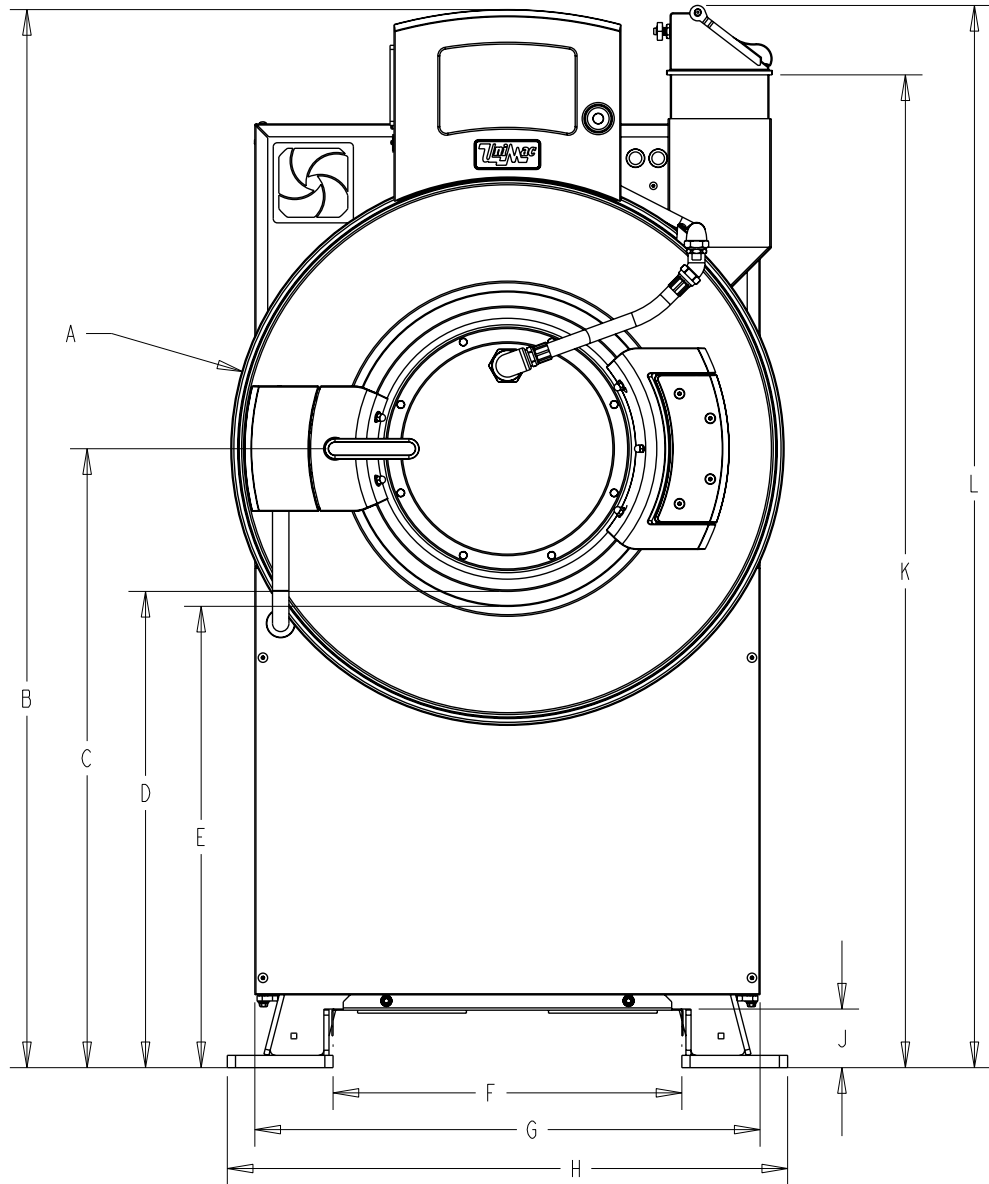

PHM965N\_SVG

**NOTE: Shown with spray and optional five compartment supply dispenser.**

Figure 2

<b>Machine Dimensions, in. [mm]</b>							
	<b>45</b>	<b>65</b>	<b>85</b>	<b>105</b>	<b>130</b>	<b>160</b>	<b>200</b>
<b>A</b>	33.7 [856]	33.7 [856]	39.4 [1001]	39.4 [1001]	45.7 [1161]	45.7 [1161]	45.7 [1161]
<b>B</b>	64.4 [1636]	64.4 [1636]	69.1 [1755]	69.1 [1755]	76.1 [1933]	76.1 [1933]	76.1 [1933]
<b>C</b>	37.7 [958]	37.7 [958]	39.3 [998]	39.3 [998]	42.9 [1090]	42.9 [1090]	42.9 [1090]
<b>D</b>	28.8 [732]	28.8 [732]	28.8 [732]	28.8 [732]	30.5 [775]	30.5 [775]	30.5 [775]
<b>E</b>	21.4 [544]	21.4 [544]	28.2 [716]	28.2 [716]	29.8 [757]	29.8 [757]	29.8 [757]
<b>F</b>	21.2 [538]	21.2 [538]	24.2 [615]	24.2 [615]	31.2 [792]	30.2 [767]	30.02 [767]
<b>G</b>	30.8 [782]	30.8 [782]	36.8 [935]	36.8 [935]	42.8 [1087]	42.8 [1087]	42.8 [1087]
<b>H</b>	34.1 [866]	34.1 [866]	40.1 [1019]	40.1 [1019]	46.1 [1171]	46.1 [1171]	46.1 [1171]
<b>J</b>	3.8 [97]	3.8 [97]	3.8 [97]	3.8 [97]	3.8 [97]	3.8 [97]	3.8 [97]
<b>K</b>	60.7 [1542]	60.7 [1542]	63.6 [1615]	63.6 [1615]	68.7 [1745]	68.7 [1745]	68.7 [1745]
<b>L</b>	64.7 [1643]	64.7 [1643]	67.6 [1717]	67.6 [1717]	72.6 [1844]	72.6 [1844]	72.6 [1844]

Table 2

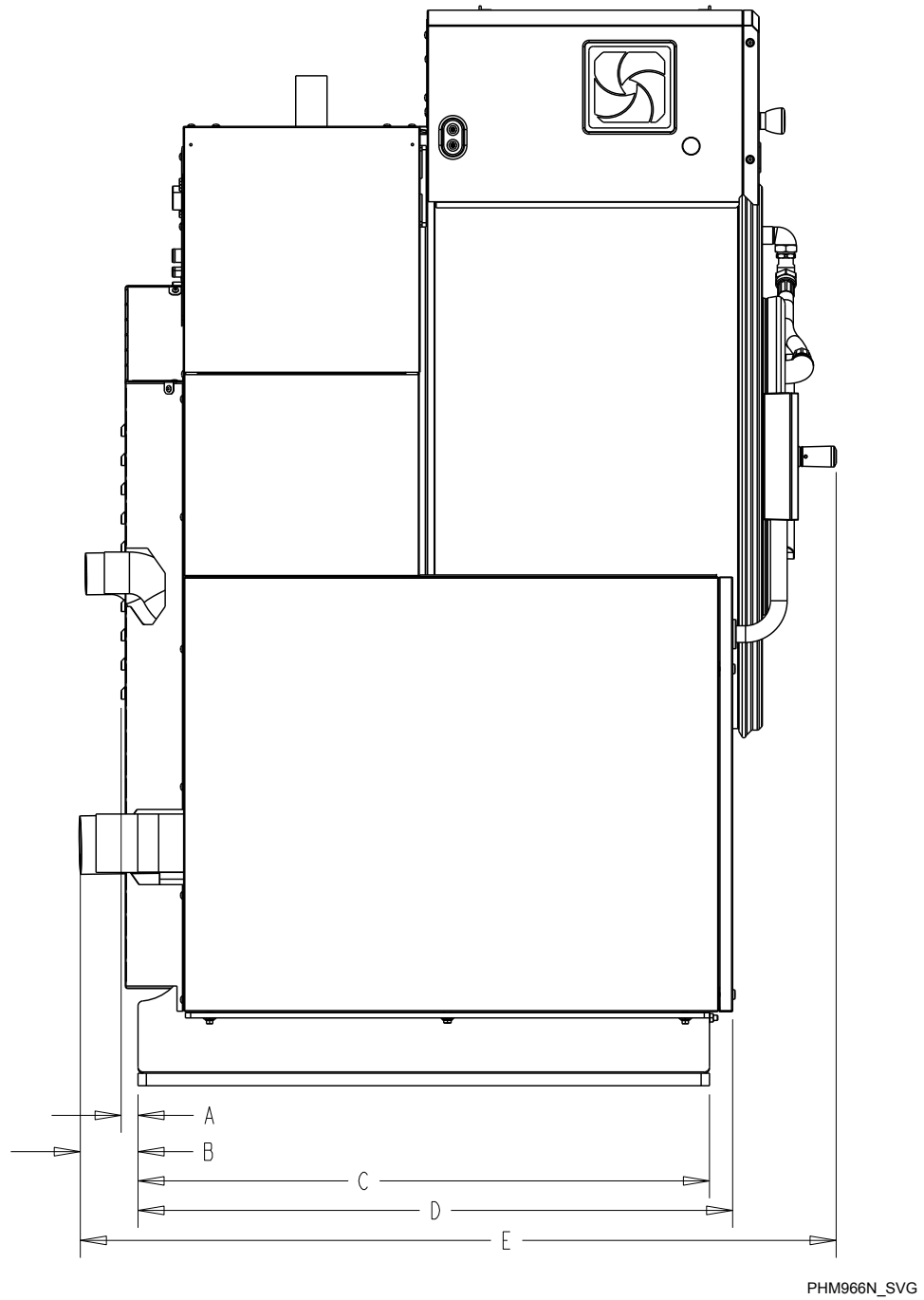

**NOTE: Shown with spray and optional five compartment supply dispenser.**

Figure 3



<b>Machine Dimensions, in. [mm]</b>							
	<b>45</b>	<b>65</b>	<b>85</b>	<b>105</b>	<b>130</b>	<b>160</b>	<b>200</b>
<b>A</b>	0.8 [20]	0.8 [20]	0.6 [15]	0.6 [15]	0.9 [23]	0.9 [23]	0.9 [23]
<b>B</b>	3.5 [89]	3.5 [89]	1.8 [46]	1.8 [46]	2.0 [51]	2.0 [51]	2.0 [51]
<b>C</b>	34.2 [869]	34.2 [869]	42.2 [1072]	42.2 [1072]	44.7 [1135]	44.7 [1135]	44.7 [1135]
<b>D</b>	35.6 [904]	41.1 [1044]	43.5 [1105]	50.5 [1283]	46.0 [1168]	51.5 [1308]	59.0 [1499]
<b>E</b>	45.3 [1151]	51.1 [1298]	51.2 [1300]	56.2 [1427]	54.5 [1384]	60.0 [1524]	67.5 [1715]
Door width	23.19 [589]	23.19 [589]	26.38 [670]	26.38 [670]	29.8 [757]	29.8 [757]	29.8 [757]
Door hinge *	2 [51]	2 [51]	2 [51]	2 [51]	2 [51]	2 [51]	2 [51]
*Machine front to hinge-side door frame (when open)							

Table 3

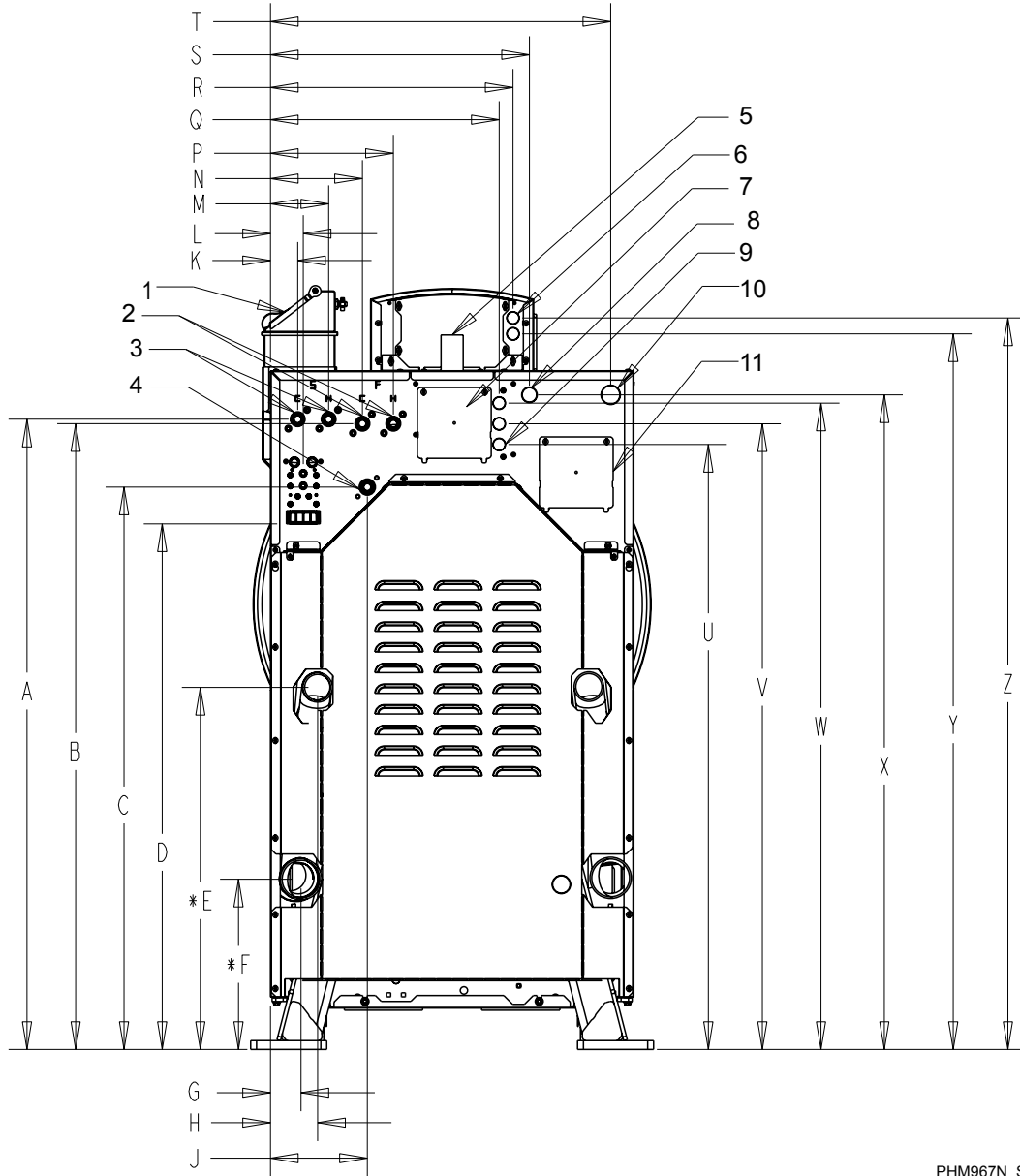

PHM967N\_SVG

**NOTE: Shown with spray and optional five compartment supply dispenser.**

- 1. Supply Dispenser
- 2. Primary Fill Connections
- 3. Spray Rinse Connections
- 4. Steam Connection
- 5. Shell Vent
- 6. .875 Electrical
- 7. Chem Supply Cover
- 8. 1.125 Electrical
- 9. .875 Chem Supply Electrical
- 10. 1.5000 Electrical
- 11. Power Access Panel

Figure 4

<b>Machine Dimensions, in. [mm]</b>							
	<b>45</b>	<b>65</b>	<b>85</b>	<b>105</b>	<b>130</b>	<b>160</b>	<b>200</b>
<b>A</b>	53.4 [1356]	53.4 [1356]	57.9 [1471]	57.9 [1471]	64.9 [1648]	64.9 [1648]	64.9 [1648]
<b>B</b>	53.0 [1346]	53.0 [1346]	57.5 [1461]	57.5 [1461]	64.5 [1638]	64.5 [1638]	54.5 [1384]
<b>C</b>	44.6 [1133]	44.6 [1133]	49.1 [1247]	49.1 [1247]	56.1 [1425]	56.1 [1425]	56.1 [1425]
<b>D</b>	47.6 [1209]	47.6 [1209]	52.2 [1326]	52.2 [1326]	56.4 [1433]	56.4 [1433]	56.4 [1433]
<b>E*</b>	30.7 [780]	30.7 [780]	30.8 [782]	30.8 [782]	29.5 [749]	29.5 [749]	29.5 [749]
<b>F*</b>	14.4 [366]	14.4 [366]	12.3 [312]	12.3 [312]	12.2 [310]	12.2 [310]	12.2 [310]
<b>G</b>	4.3 [109]	5.9 [150]	2.5 [64]	2.5 [64]	2.9 [74]	2.9 [74]	2.9 [74]
<b>H</b>	3.6 [91]	3.6 [91]	2.6 [66]	2.6 [66]	2.9 [74]	2.9 [74]	2.9 [74]
<b>J</b>	8.2 [208]	8.2 [208]	8.2 [208]	8.2 [208]	7.7 [196]	7.7 [196]	7.7 [196]
<b>K</b>	2.3 [58]	2.3 [58]	2.3 [58]	2.3 [58]	2.3 [58]	2.3 [58]	2.3 [58]
<b>L</b>	2.8 [71]	2.8 [71]	2.8 [71]	2.8 [71]	2.8 [71]	2.8 [71]	2.8 [71]
<b>M</b>	4.9 [124]	4.9 [124]	4.9 [124]	4.9 [124]	4.9 [124]	4.9 [124]	4.9 [124]
<b>N</b>	7.8 [198]	7.8 [198]	8.3 [211]	8.3 [211]	8.3 [211]	8.3 [211]	8.3 [211]
<b>P</b>	10.4 [264]	10.4 [264]	11.4 [290]	11.4 [290]	11.4 [290]	11.4 [290]	11.4 [290]
<b>Q</b>	19.4 [493]	19.4 [493]	22.4 [569]	22.4 [569]	25.4 [645]	25.4 [645]	25.4 [645]
<b>R</b>	20.5 [521]	20.5 [521]	23.5 [597]	23.5 [597]	26.5 [673]	26.5 [673]	26.5 [673]
<b>S</b>	21.9 [556]	21.9 [556]	27.9 [709]	27.9 [709]	33.9 [861]	33.9 [861]	33.9 [861]
<b>T</b>	28.8 [732]	28.8 [732]	34.8 [884]	34.8 [884]	40.8 [1086]	40.8 [1086]	40.8 [1086]
<b>U</b>	51.2 [1300]	51.2 [1300]	56.1 [1425]	56.1 [1425]	63.1 [1603]	63.1 [1603]	63.1 [1603]
<b>V</b>	53.0 [1346]	53.0 [1346]	57.8 [1468]	57.8 [1468]	64.8 [1646]	64.8 [1646]	64.8 [1646]
<b>W</b>	54.7 [1389]	54.7 [1389]	59.6 [1514]	59.6 [1514]	66.6 [1692]	66.6 [1692]	66.6 [1692]
<b>X</b>	55.4 [1407]	55.4 [1407]	53.7 [1364]	60.0 [1524]	67.0 [1702]	67.0 [1702]	67.0 [1702]
<b>Y</b>	60.6 [1539]	60.6 [1539]	65.2 [1656]	65.2 [1656]	72.2 [1834]	72.2 [1834]	72.2 [1834]
<b>Z</b>	61.94 [1573]	61.94 [1573]	66.59 [1691]	66.59 [1691]	73.56 [1868]	73.56 [1868]	73.56 [1868]
*Dual Drain only used on 85-200 D3 and D4 models							

Table 4

# Mounting Bolt Hole Locations - 45 and 65 Pound Models

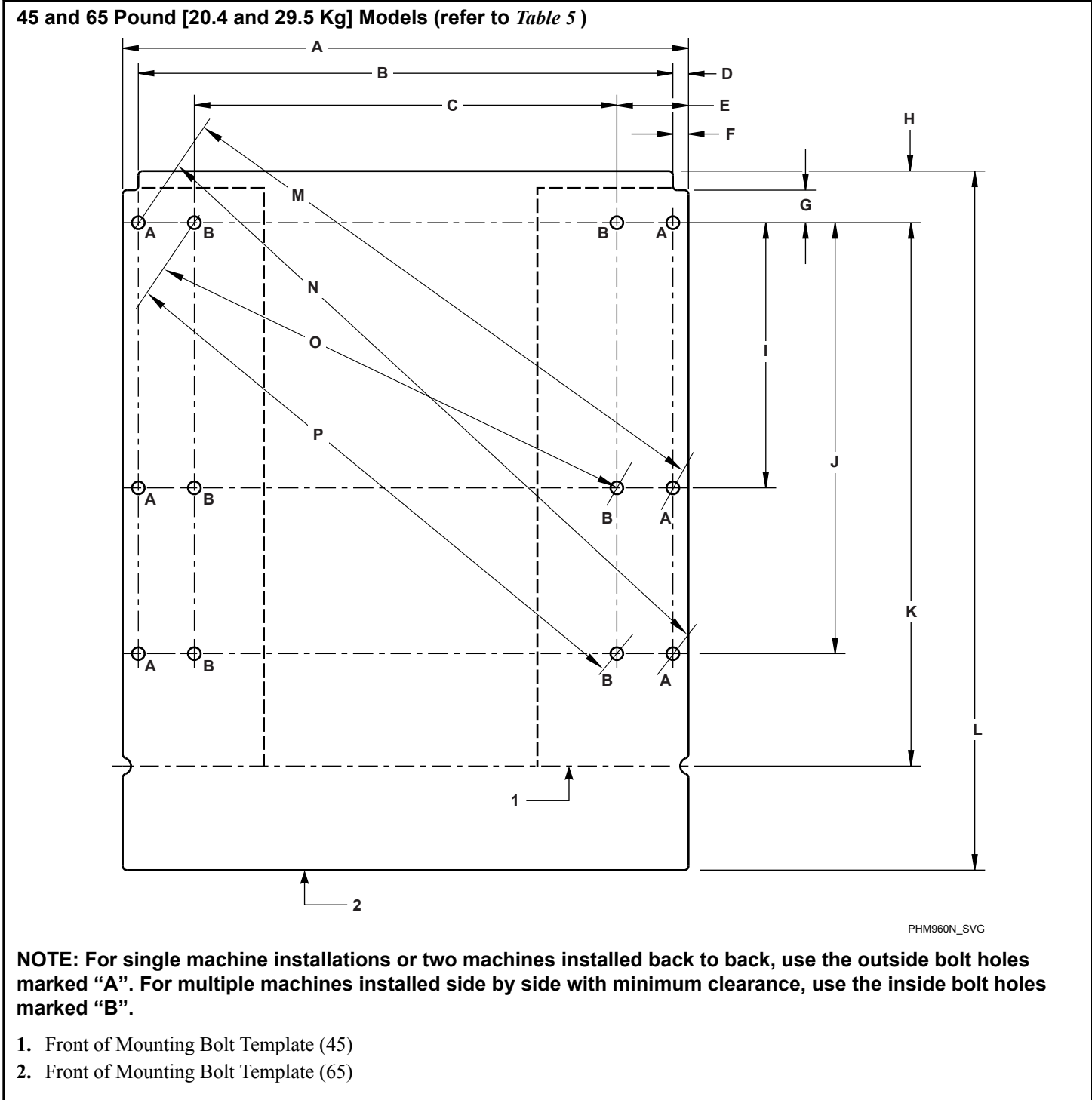

Figure 5

<b>Mounting Bolt Hole Locations – 45 and 65 Pound [20.4 and 29.5 Kg] Models, in. [mm]</b>			
		<b>45</b>	<b>65</b>
<b>A</b>		34.12 [867]	34.12 [867]
<b>B</b>		32.24 [819]	32.24 [819]
<b>C</b>		25.48 [647]	25.48 [647]
<b>D</b>		0.94 [24]	0.94 [24]
<b>E</b>		4.32 [110]	4.32 [110]
<b>F</b>		0.94 [24]	0.94 [24]
<b>G</b>		1.96 [50]	1.96 [50]
<b>H</b>		3 [76]	3 [76]
<b>I</b>		16 [406]	16 [406]
<b>J</b>		26 [660]	26 [660]
<b>K</b>		33.67 [855]	Not Applicable
<b>L</b>		Not Applicable	42.17 [1071]
<b>M</b>	Outside	35.99 [914]	35.99 [914]
<b>N</b>		41.41 [1051]	41.41 [1051]
<b>O</b>	Inside	30.08 [764]	30.08 [764]
<b>P</b>		36.4 [924]	36.4 [924]

Table 5

# Mounting Bolt Hole Locations - 85 and 105 Pound Models

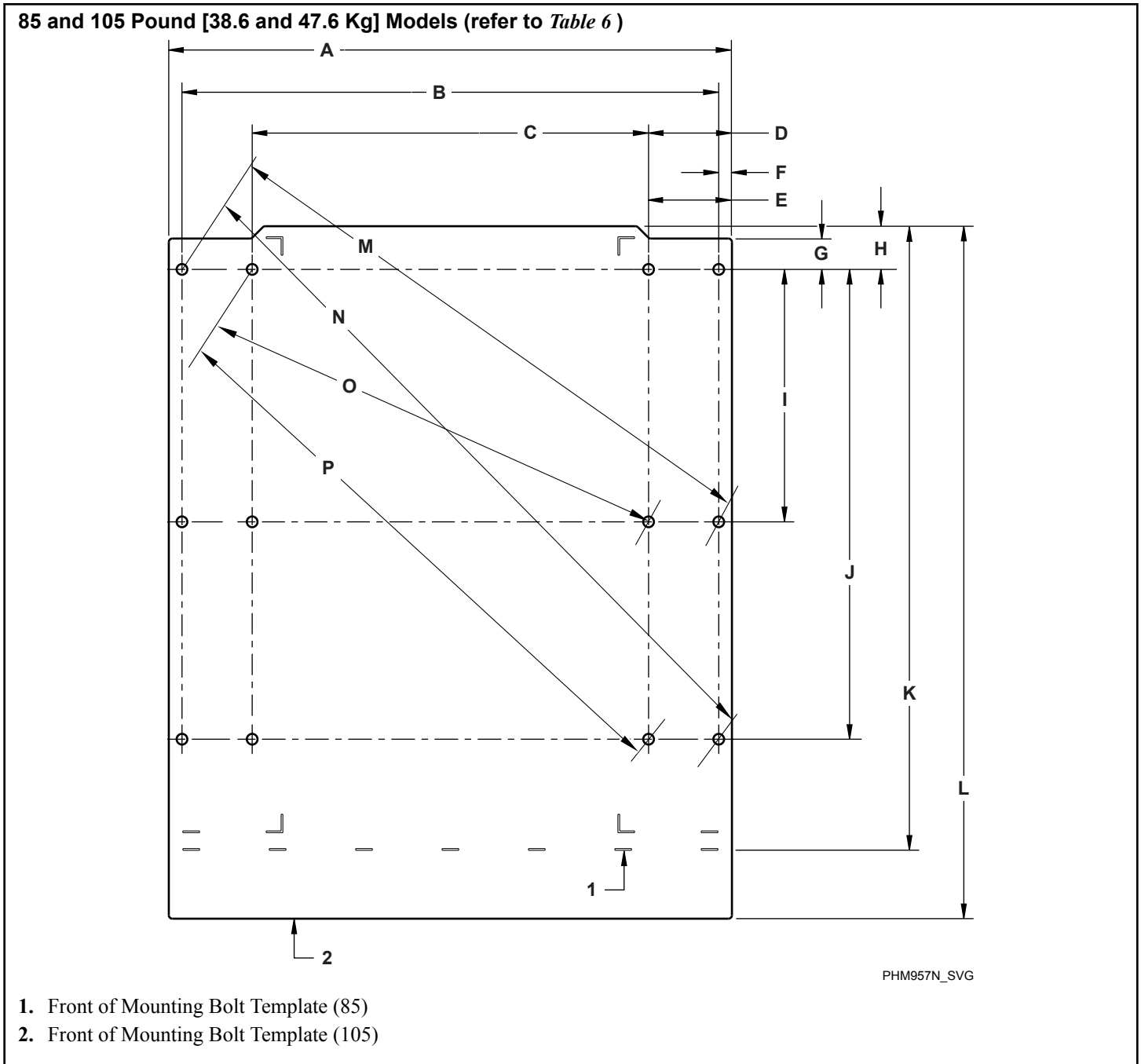

Figure 6

<b>Mounting Bolt Hole Locations – 85 and 105 Pound [38.6 and 47.6 Kg] Models, in. [mm]</b>			
		<b>85</b>	<b>105</b>
<b>A</b>		40.12 [1019]	40.12 [1019]
<b>B</b>		38.24 [971]	38.24 [971]
<b>C</b>		28.24 [717]	28.24 [717]
<b>D</b>		5.94 [151]	5.94 [151]
<b>E</b>		5.89 [149]	5.89 [149]
<b>F</b>		0.94 [24]	0.94 [24]
<b>G</b>		2.20 [56]	2.20 [56]
<b>H</b>		3.08 [78]	3.08 [78]
<b>I</b>		18 [457]	18 [457]
<b>J</b>		33.50 [851]	33.50 [851]
<b>K</b>		44.38 [1127]	Not Applicable
<b>L</b>		Not Applicable	49.38 [1254]
<b>M</b>	Outside	42.27 [1074]	42.27 [1074]
<b>N</b>		50.84 [1291]	50.84 [1291]
<b>O</b>	Inside	33.49 [851]	33.49 [851]
<b>P</b>		43.82 [1113]	43.82 [1113]

Table 6

# Mounting Bolt Hole Locations - 130-200 Pound Models

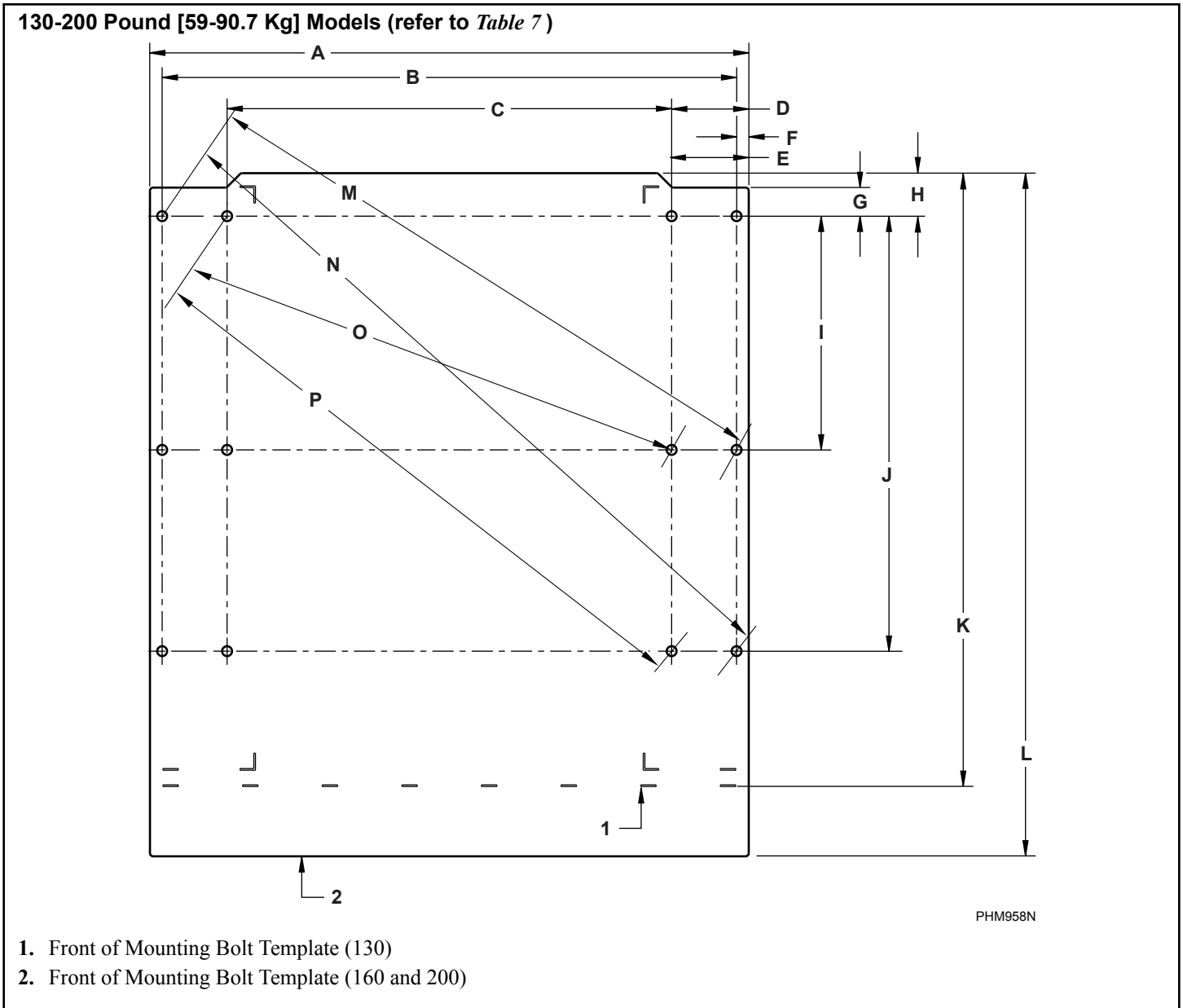

Figure 7

Mounting Bolt Hole Locations – 130-200 Pound [59-90.7 Kg] Models, in. [mm]		
	130	160-200
<b>A</b>	46.12 [1171]	46.12 [1171]
<b>B</b>	44.24 [1124]	44.24 [1124]
<b>C</b>	34.24 [870]	34.24 [870]

Table 7 continues...



<b>Mounting Bolt Hole Locations – 130-200 Pound [59-90.7 Kg] Models, in. [mm]</b>			
		<b>130</b>	<b>160-200</b>
<b>D</b>		5.94 [151]	5.94 [151]
<b>E</b>		5.89 [150]	5.89 [150]
<b>F</b>		0.94 [24]	0.94 [24]
<b>G</b>		2.20 [56]	2.20 [56]
<b>H</b>		3.31 [84]	3.31 [84]
<b>I</b>		18 [457]	18 [457]
<b>J</b>		33.50 [851]	33.50 [851]
<b>K</b>		47.11 [1197]	Not Applicable
<b>L</b>		Not Applicable	52.61 [1336]
<b>M</b>	Outside	47.76 [1213]	47.76 [1213]
<b>N</b>		55.49 [1409]	55.49 [1409]
<b>O</b>	Inside	43.17 [1097]	43.17 [1097]
<b>P</b>		47.90 [1217]	47.90 [1217]

Table 7

# Installation

## Foundation Options

A minimum 3500 psi (refer to rating per supplier) reinforced concrete set on a prepared bed is required for all new machine installations.

**NOTE: Do not mount on metal base frames, wooden floors, tile floors, elevated floor levels, or over basements or crawl spaces because of the high extract speed and the G-forces exerted.**

Thoroughness of detail must be stressed with all foundation work to ensure a stable unit installation, eliminating possibilities of excessive vibration during extract.

For new foundations a mounting bolt template is available at extra cost or use machine base if available.

The machine must be anchored to a smooth level surface so that the entire base of the machine is supported and rests on the mounting surface.

**IMPORTANT: Do not permanently support the machine on only four points with spacers. Grouting is required and spacers must be removed.**

### Machine Installation on Existing Floor

The existing floor slab must be reinforced concrete without voids under slab and meet depth requirements per *Table 13*. If the floor meets these requirements and an elevated pad is NOT desired, refer to *Figure 11* and proceed to *Machine Mounting and Grouting*.

If the floor does not meet these requirements and an elevated pad is NOT desired, refer to *Figure 14* and proceed to *Machine Mounting and Grouting*.

### Elevated Pad Installation on Existing Floor

The existing floor slab must be 6 inches [152 mm] thick reinforced concrete without voids under slab. If the slab meets these requirements and an elevated pad is desired, refer to *Figure 13* and proceed to *Foundation and Pad Installation*.

### New Foundation

If the existing floor slab does not meet the single machine foundation requirements per model and/or a new monolithic foundation is desired, refer to *Figure 12* and proceed to *Foundation and Pad Installation*.

### Isolated Pad Installation

This type of installation is NOT recommended. Installer MUST consult a Structural Engineer for concrete specifications and requirements for installations that will not be tied into adjacent foundations.

**IMPORTANT: The above instructions and recommendations are conservative specifications for a typical installation based on consultations with a structural engineer. Alliance Laundry Systems stands behind all installations meeting these specifications. For alternate installation specifications based on your soil type, location, building structure, unique floor geometry, machine types, and utilities, consult a structural engineer in your local area.**

## Foundation and Pad Installation

A concrete pad may be constructed to elevate a machine. Care must be exercised in the design of the pad due to the force exerted by the machine during extract. This concrete pad, recommend-

**IMPORTANT: Do NOT install a pad on top of the existing floor. The foundation and pad must be constructed and tied together as one piece.**

If the existing floor is not reinforced concrete at least 12 inches [305 mm] thick, an elevated pad is desired or multiple machines are to be installed, the following steps must be performed (refer to *Foundation Requirements*):

1. Cut a hole through the existing floor that is larger on all sides than the machine base, refer to *Floor Layout and Pad Dimensions*.
2. Excavate to a depth as indicated in *Table 12* from the top of the existing floor.
3. If installing a foundation with elevated pad, prepare a form for the above-ground portion of the foundation. Verify that the top of the foundation is level. The height of the foundation pad must not exceed 8 inches [203 mm] above the existing floor.
4. Backfill with clean fill dirt.
5. Compact backfill, making sure to allow for correct concrete thickness.
6. Drill holes (refer to manufacturer's requirements for drill hole size) for the perimeter reinforcing bar at a depth of 2-1/2 inches [64 mm] into the existing floor. The reinforcing should be 12 inches [305 mm] on center each way around entire perimeter.
7. Clean out debris from each reinforcing bar hole.

ed not to exceed 8 inches [203 mm] above existing floor, must be placed, reinforced with rebar and tied to the existing floor. Refer to and *Foundation Requirements* sections for multiple machine installations.

8. Fill half the hole depth with acrylic adhesive.

**NOTE: Procure acrylic adhesive rated for commercial-grade vibratory machine installations**

9. Using #4 [60 ksi] reinforcing bar, tie new pad to existing floor making sure to tie reinforcing bars at the intersections and using proper reinforcing bar supports to hold bars at the proper depth in the pad.
10. Allow adhesive around reinforcing bar to cure properly, refer to adhesive manufacturer for recommended cure times.
11. Completely fill with 3500 psi concrete up to the existing foundation level plus any added level (maximum of 8 inch [203 mm]) for the desired elevated pad. The concrete must be poured so that the entire foundation and pad cures as one piece.
12. Allow concrete to cure, refer to manufacturer's recommended cure times.
13. Using a mounting bolt template or machine base, mark where the holes should be drilled to mount the machine.
 

**NOTE: As an alternate method, cast in the Grade 5 (minimum SAE rating), 3/4 inch [19 mm] anchor bolts as the concrete is poured, refer to *Figure 16*. Ensure that the bolt threads extend a minimum of 2-3/4 inches [70 mm] above floor level and a minimum of 6 inches [152 mm] of the bolt is embedded in concrete.**
14. Proceed to *Machine Mounting and Grouting*.

## Floor Layout and Pad Dimensions

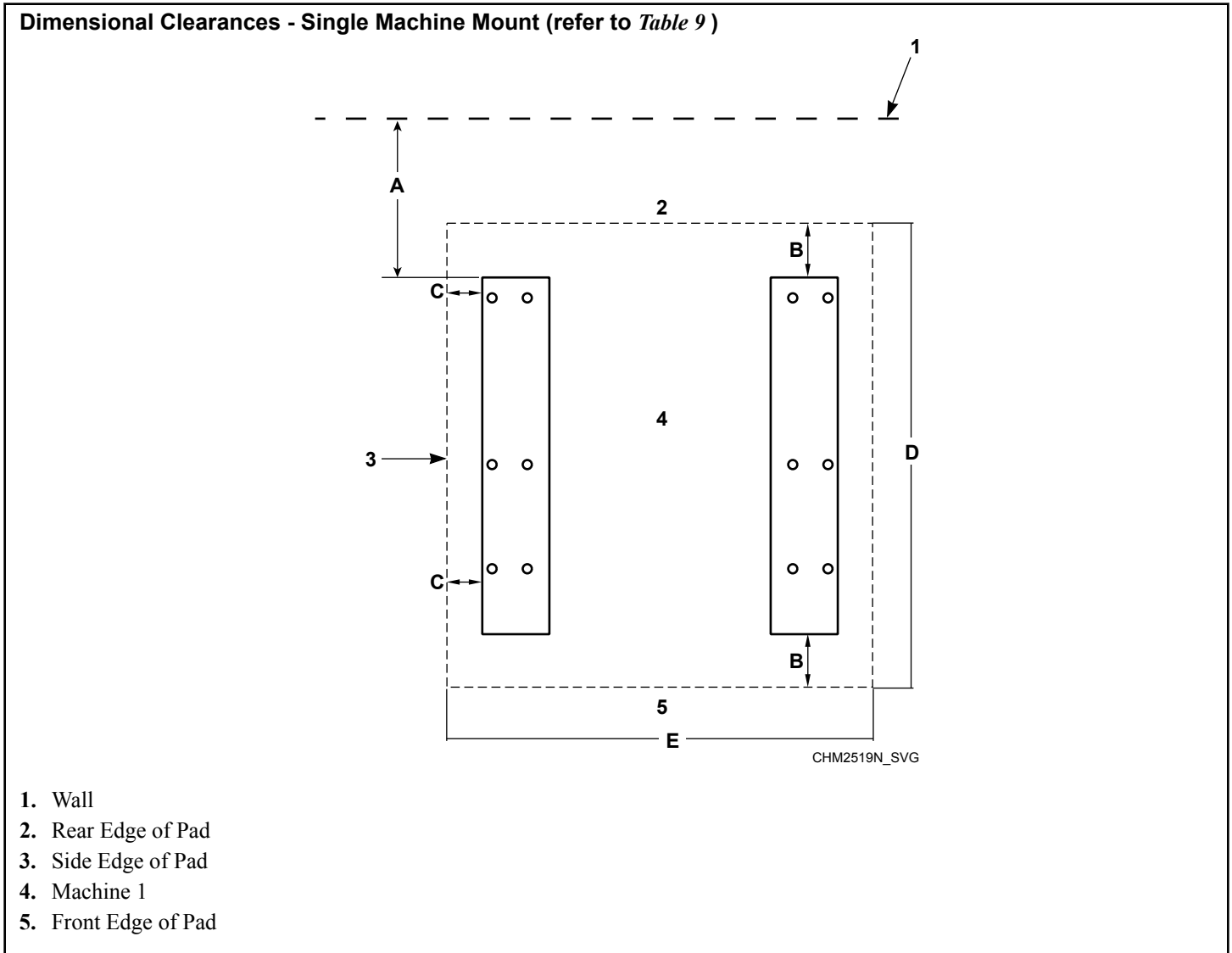

Figure 8

Single Machine Mount, in. [mm]					
Description			45-65	85-105	130-200
<b>A-</b>	Distance to wall (minimum)		20 [508]	20 [508]	20 [508]
<b>B</b>	Distance of machine base to front/rear edge of pad (minimum)	Standard	12 [305]	12 [305]	16 [407]
		Narrow*	9 [226]	9 [226]	9 [226]
		Ultra-narrow*	6 [153]	6 [153]	6 [153]

Table 9 continues...

Single Machine Mount, in. [mm]					
Description			45-65	85-105	130-200
C	Distance of machine base to side edge of pad (minimum)	Standard	12 [305]	12 [305]	16 [407]
		Narrow*	9 [226]	9 [226]	9 [226]
		Ultra-narrow*	6 [153]	6 [153]	6 [153]
D-	Length of pad (minimum)		60 [1524]	67.75 [1721]	80 [2032]
E-	Width of pad (minimum)		60 [1524]	65.12 [1654]	74.25 [1886]
*Requires additional concrete depth and rebar. Refer to <i>Table 12</i> and <i>Foundation Requirements</i> .					

Table 9

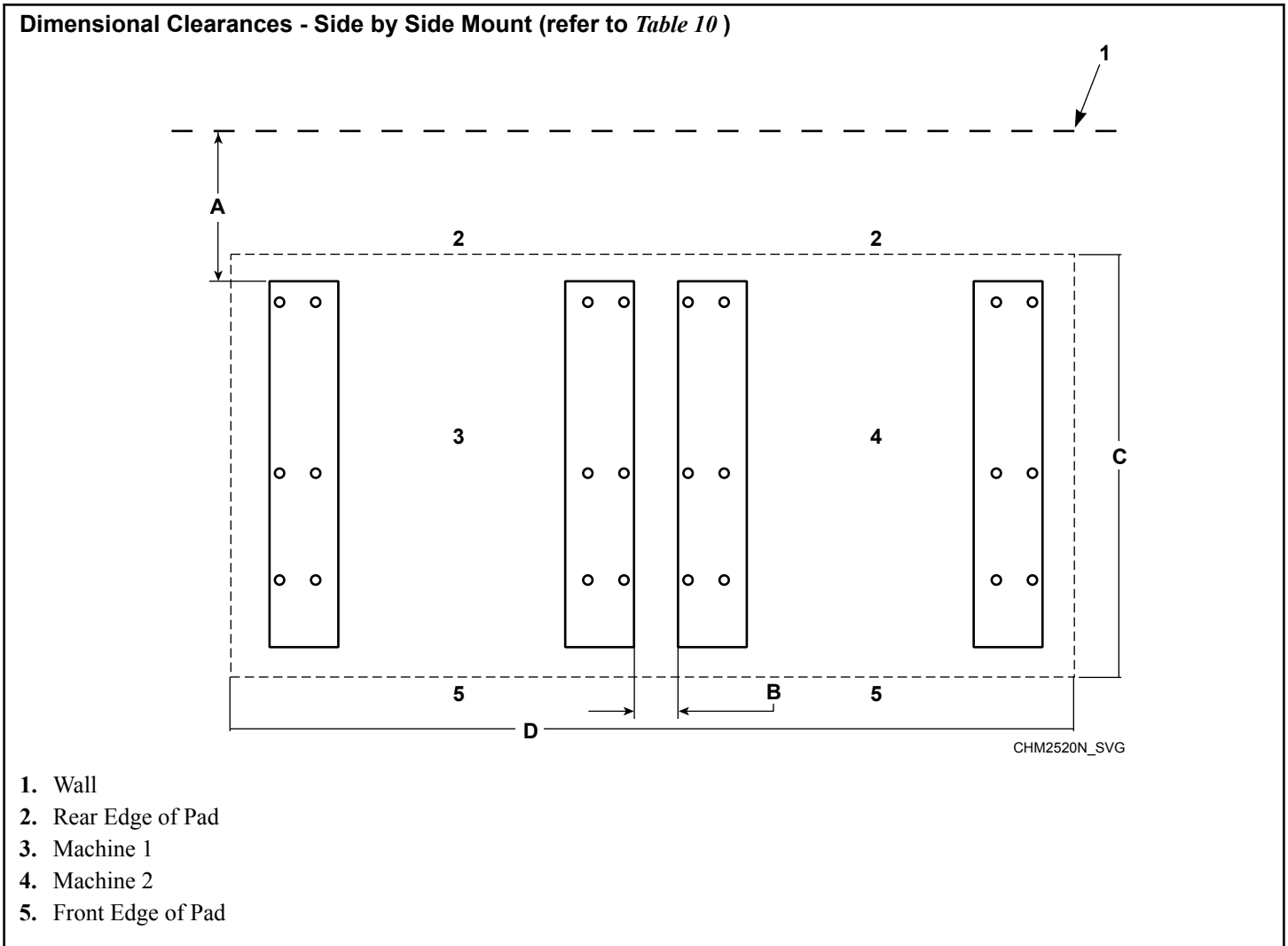

Figure 9

Side-by-Side Mount, in. [mm]					
Description			45-65	85-105	130-200
A-	Distance to wall (minimum)		20 [508]	20 [508]	20 [508]
B-	Adjacent unit spacing (minimum)	Standard	18 [457]	18 [457]	18 [457]
		Narrow*	12 [305]	12 [305]	12 [305]
		Ultra-narrow*	6 [153]	6 [153]	6 [153]
C-	Length of pad (minimum)	2 machines	60 [1524]	67.75 [1721]	80 [2032]
		3 machines	60 [1524]	67.75 [1721]	80 [2032]
D-	Width of pad (minimum)	2 machines	98 [2489]	123.25 [3131]	138.38 [3515]
		3 machines	138 [3505]	181.37 [4607]	202.5 [5144]

Table 10 continues...

Side-by-Side Mount, in. [mm]			
Description	45-65	85-105	130-200
*Requires additional concrete depth and rebar. Refer to <i>Table 12</i> and <i>Foundation Requirements</i> .			

Table 10

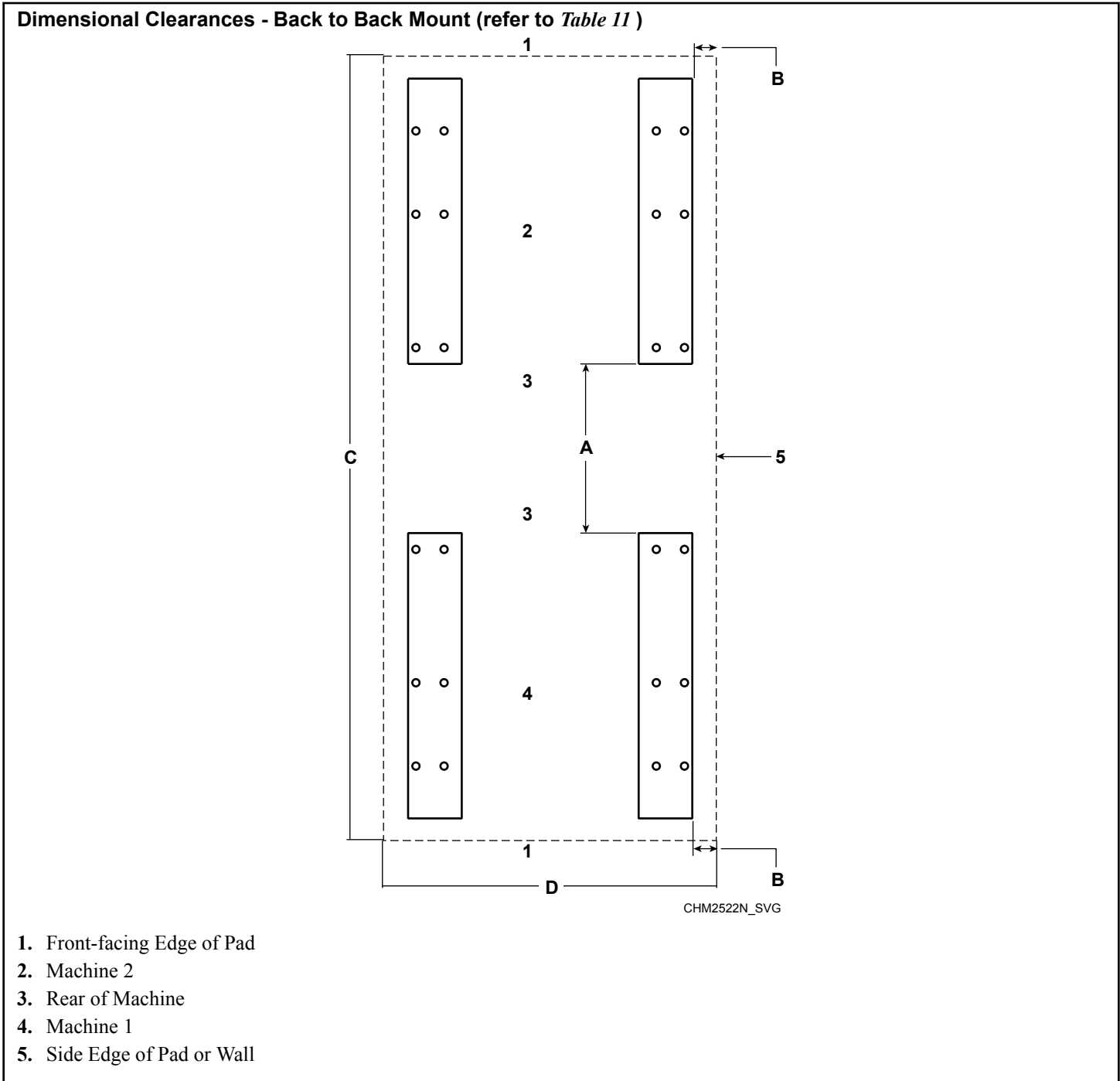

Figure 10

Back-to-Back Mount, in. [mm]					
Description		45-65	85-105	130-200	
<b>A-</b>	Adjacent rear spacing (minimum)	20 [508]	20 [508]	20 [508]	
<b>B-</b>	Distance of machine base to edge of pad (minimum)	Standard	12 [305]	12 [305]	16 [407]
		Narrow*	9 [226]	9 [226]	9 [226]
		Ultra-narrow*	6 [153]	6 [153]	6 [153]
<b>C-</b>	Length of pad (minimum)	106 [2692]	135.5 [3442]	160 [4064]	
<b>D-</b>	Width of pad (minimum)	60 [1524]	65.12 [1654]	74.25 [1886]	
*Requires additional concrete depth and rebar. Refer to <i>Table 12</i> and <i>Foundation Requirements</i> .					

Table 11

Pad Thickness Requirements, in. [mm]					
Specifications		45	65	85-105	130-200
Minimum Foundation Thickness*	L-speed	6 [152]	6 [152]	N/A	N/A
	M-speed	6 [152]	8 [203]	12 [305]	12 [305]
	V-speed	12 [305]	12 [305]	12 [305]	12 [305]
Minimum Excavation Depth	L-speed	12 [305]	12 [305]	N/A	N/A
	M-speed	12 [305]	14 [356]	18 [457]	18 [457]
	V-speed	18 [457]	18 [457]	18 [457]	18 [457]
*Installing additional concrete mass (thicker foundation) will further reduce vibration and install risk.					

Table 12



# Foundation Requirements

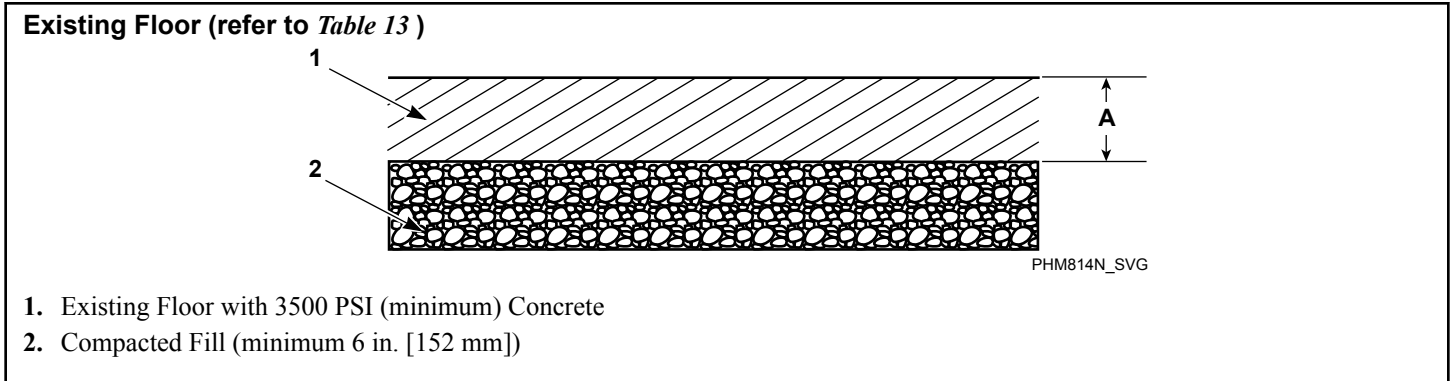

Figure 11

		Existing Floor, in. [mm]					
Description		L-speed / 45 (M-speed)	65 (M-speed)	45-65 (V-speed)	85-105	130-200	
A	Required thickness of existing floor (minimum)	Standard*	6 [152]	8 [203]	12 [305]	12 [305]	12 [305]
		Narrow*	8 [203]	10 [254]	14 [356]	14 [356]	14 [356] (Side-by-side) 18 [457] (Back-to-back)
		Ultra-narrow*	10 [254]	12 [305]	16 [406]	16 [406]	20 [508] (Side-by-side) 20 [508] (Back-to-back)
* Refer to <i>Floor Layout and Pad Dimensions</i> .							

Table 13

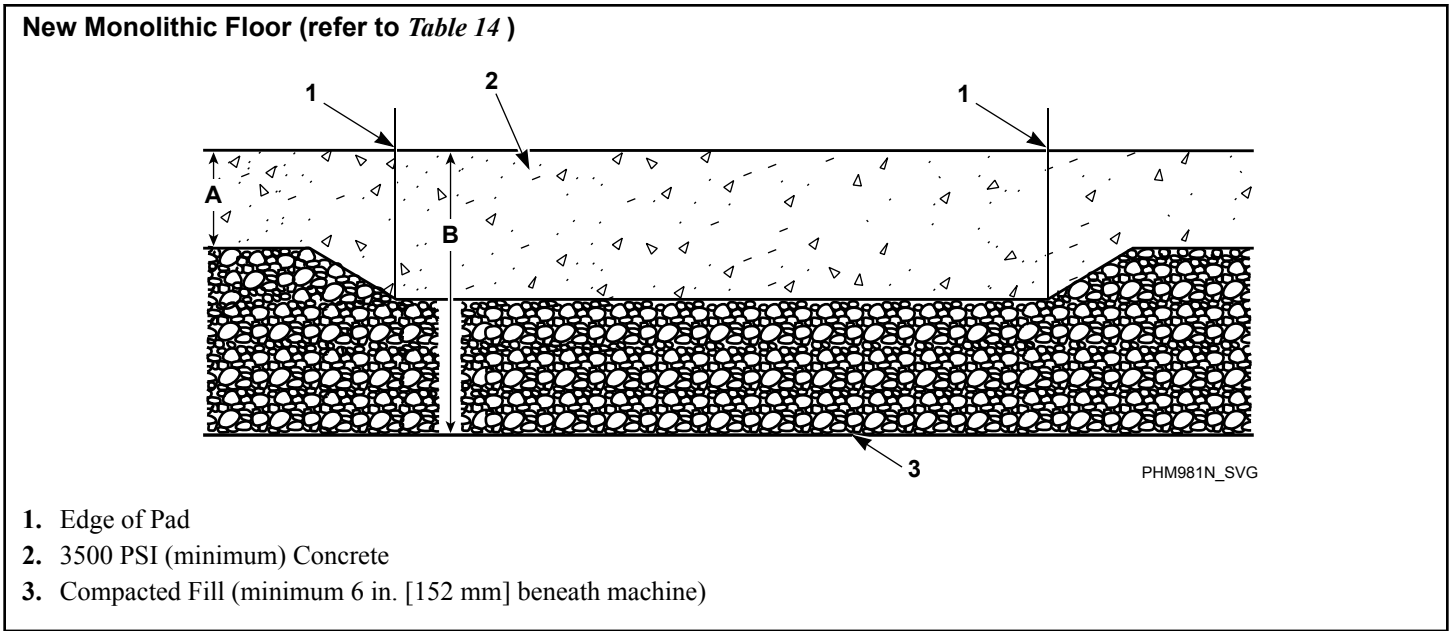

Figure 12

New Monolithic Floor, in. [mm]							
Description		L-speed / 45 (M-speed)	65 (M-speed)	45-65 (V-speed)	85-105	130-200	
<b>A</b>	<b>Depth of Surrounding Floor</b>	6 [152]	6 [152]	6 [152]	6 [152]	6 [152]	
<b>B</b>	<b>Total depth of foundation (concrete plus 6 in. [152 mm] fill) (minimum)</b>	Standard*	12 [305]	14 [356]	18 [457]	18 [457]	
		Narrow*	14 [356]	16 [406]	20 [508]	20 [508]	20 [508] (Side-by-side) 24 [610] (Back-to-back)
		Ultra-narrow*	16 [406]	18 [457]	22 [559]	22 [559]	26 [660] (Side-by-side) 26 [660] (Back-to-back)
* Refer to <i>Floor Layout and Pad Dimensions</i> .							

Table 14

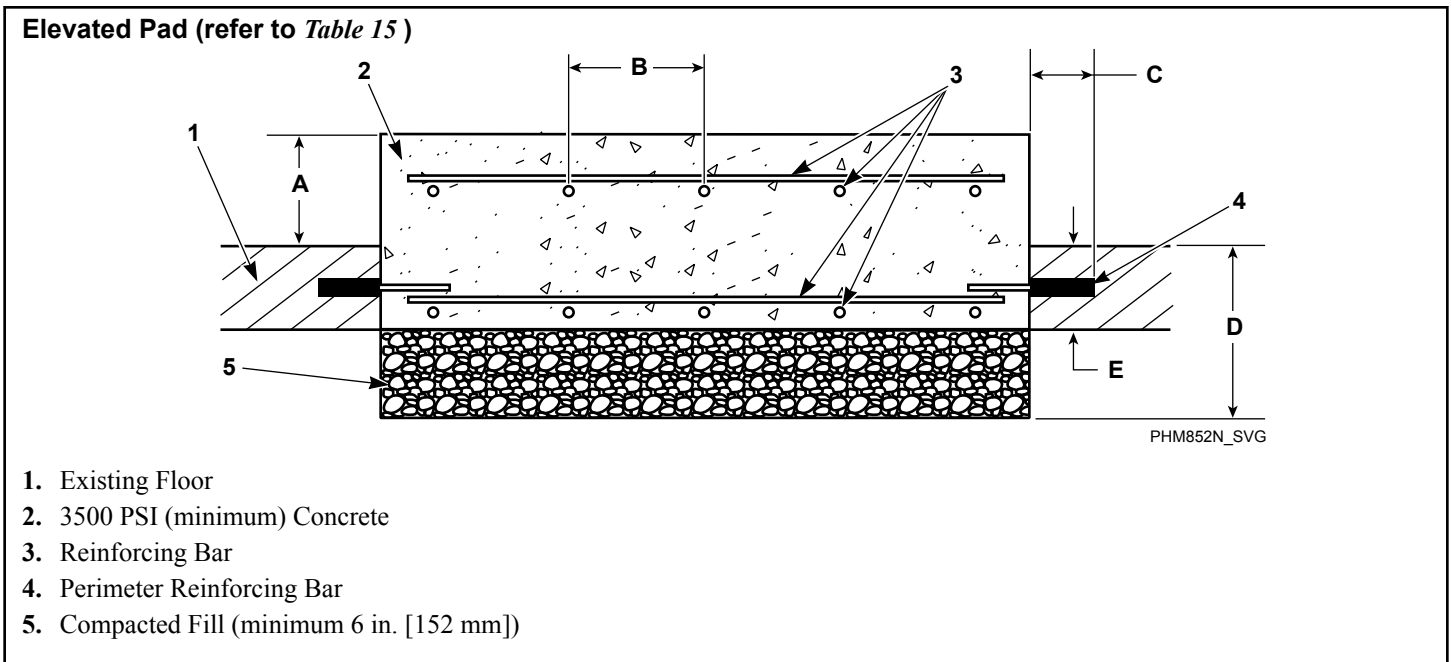

Figure 13

Elevated Pad, in. [mm]						
Description		L-speed / 45 (M-speed)	65 (M-speed)	45-65 (V-speed)	85-105	130-200
<b>A</b>	<b>Height of elevated pad above floor (maximum)</b>	8 [203]	8 [203]	8 [203]	8 [203]	8 [203]
<b>B</b>	<b>Distance between reinforcing bars (maximum)</b>	Standard*	12 [305]	12 [305]	12 [305]	12 [305]
		Narrow*	6 [152]	6 [152]	6 [152]	6 [152]
		Ultra-narrow*	6 [152]	6 [152]	6 [152]	6 [152]
<b>C</b>	<b>Length of reinforcing bar extending into existing Floor (minimum)</b>	2.5 [64]	2.5 [64]	2.5 [64]	2.5 [64]	2.5 [64]

Table 15 continues...

Elevated Pad, in. [mm]							
Description			L-speed / 45 (M-speed)	65 (M-speed)	45-65 (V-speed)	85-105	130-200
<b>D</b>	<b>Total depth of foundation (concrete plus 6 in. [152 mm] fill) (minimum)</b>	Standard*	12 [305]	14 [356]	18 [457]	18 [457]	18 [457]
		Narrow*	14 [356]	16 [406]	20 [508]	20 [508]	20 [508] (Side-by-side) 24 [610] (Back-to-back)
		Ultra-narrow*	16 [406]	18 [457]	22 [559]	22 [559]	26 [660] (Side-by-side) 26 [660] (Back-to-back)
<b>E</b>	<b>Required thickness of existing floor (minimum)</b>	6 [152]	6 [152]	6 [152]	6 [152]	6 [152]	6 [152]
* Refer to <i>Floor Layout and Pad Dimensions</i> .							

Table 15

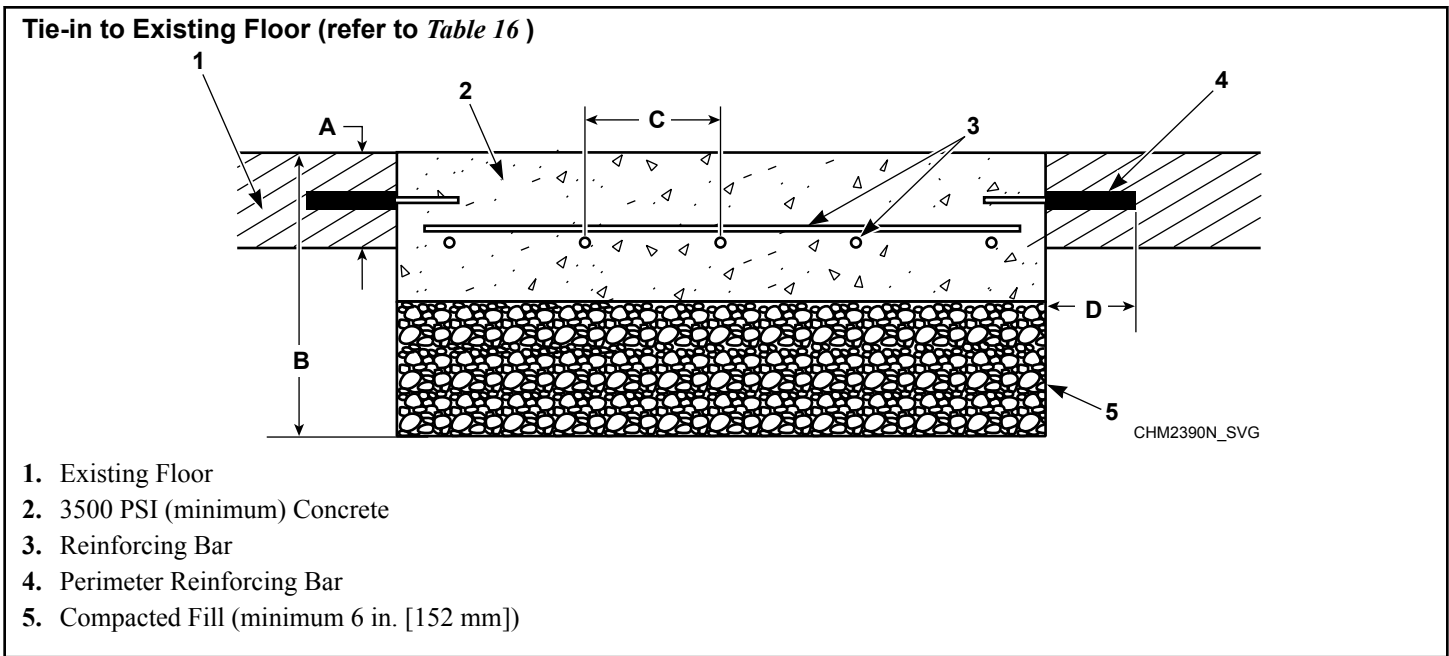

Figure 14

Tie-in to Existing Floor, in. [mm]							
Description		L-speed / 45 (M-speed)	65 (M-speed)	45-65 (V-speed)	85-105	130-200	
<b>A</b>	<b>Required thickness of existing floor (minimum)</b>	6 [152]	6 [152]	6 [152]	6 [152]	6 [152]	
<b>B</b>	<b>Total depth of foundation (concrete plus 6 in. [152 mm] fill)(minimum)</b>	Standard*	12 [305]	14 [356]	18 [457]	18 [457]	
		Narrow*	14 [356]	16 [406]	20 [508]	20 [508]	24 [610] (Back-to-back)
		Ultra-narrow*	16 [406]	18 [457]	22 [559]	22 [559]	26 [660] (Back-to-back)
<b>C</b>	<b>Distance between reinforcing bars (maximum)</b>	Standard*	12 [305]	12 [305]	12 [305]	12 [305]	
		Narrow*	6 [152]	6 [152]	6 [152]	6 [152]	
		Ultra-narrow*	6 [152]	6 [152]	6 [152]	6 [152]	

Table 16 continues...

Tie-in to Existing Floor, in. [mm]						
Description		L-speed / 45 (M-speed)	65 (M-speed)	45-65 (V-speed)	85-105	130-200
<b>D</b>	<b>Length of reinforcing bar extending into existing floor (minimum)</b>	2.5 [64]	2.5 [64]	2.5 [64]	2.5 [64]	2.5 [64]
* Refer to <i>Floor Layout and Pad Dimensions</i> .						

Table 16

## Machine Mounting and Grouting

**NOTE:** After the concrete has cured completely and the cast-in-place method was used, refer to *Figure 16* and proceed to step 7. If acrylic adhesive anchors are desired, refer to *Figure 15* and proceed with step 1 after concrete has cured completely.

1. Refer to *Figure 15* to set the drill depth gauge.
2. Drill the holes to the set depth.
3. Use compressed air or squeeze bulb to clean out debris from each hole. Use a vacuum to remove fine dust.
4. Fill half the hole depth with an industry-accepted adhesive anchoring system.
5. Insert anchor bolt until it reaches the bottom and a minimum of 2-3/4 in. [70 mm] extends above surface and a minimum of 6 inches [152 mm] is embedded in concrete.
6. Ensure all air pockets are removed from adhesive surrounding the bolt.
7. Allow adhesive around bolt to cure completely.

**IMPORTANT:** Refer to bolt manufacturer's recommended adhesive cure times.

8. Remove shipping materials and place the machine carefully over the bolts. Never attempt to lift the machine by the door handle or by pushing on the cover panels. Always insert a pry bar or other lifting device under the bottom frame of the machine to move it.
9. Raise and level the machine 1/2 inch [12.7 mm] off the floor on four corners, using spacers such as nut fasteners.

10. Following the manufacturer's instructions, mix a good quality **non-shrinking machinery precision grout**. The grout should not be too runny or too dry and should flow into place easily. Completely fill the space between the machine base and the floor with grout to ensure a stable installation. Grout completely under frame (if bolted with inside pattern, remove front panel and back panel to gain access to all frame members). Refer to *Figure 5*. Force grout under machine base until all voids are filled.

**IMPORTANT:** Minimum Grade 5, SAE rating, flat washers and minimum Grade 5, SAE rating, serrated hex flange locknuts are the recommended hardware for anchoring machine to bolts.

11. Position the flat washers and locknuts on the anchor bolts and finger-tighten to machine base.
12. Allow machine grout to set (stiffen), but not cure.
13. **Remove the spacers carefully, allowing the machine to settle into the wet grout.** Pack any remaining voids with grout.
14. After the grout is completely cured, torque the locknuts to 160 ± 16 ft.-lbs. – one after the other – until all are tightened evenly and the machine is fastened securely to the floor.

**IMPORTANT:** Refer to recommended grout cure times from manufacturer before torquing locknuts.

**IMPORTANT:** All torque joints must remain dry (non-lubricated).

**NOTE:** Check and retighten the locknuts after five to ten days of operation and every month thereafter.

	<b>WARNING</b>
<p><b>Crush hazard. To avoid personal injury and/or property damage, do not tip the machine more than 25 degrees in any direction.</b></p>	
W793	

**Acrylic Adhesive Anchors (refer to Table 17)**

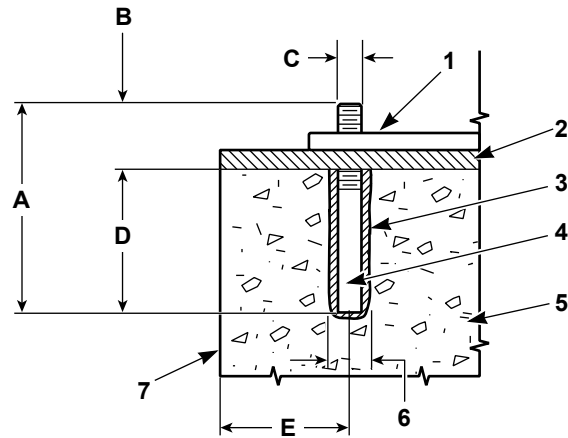

PHM811N\_SVG

**NOTE: \*Available for purchase through the distributor. If not purchasing from a distributor, procure acrylic adhesive rated for commercial-grade vibratory machine installations.**

1. Machine Frame Base
2. Grout 1/2 in. [13 mm]
3. Acrylic Adhesive\*
4. Anchor Bolt\* (minimum Grade 5 SAE rating)
5. Concrete
6. Drill Hole Size per Manufacturer Requirements
7. Edge of Pad

Figure 15

**Cast-in-place Anchors (refer to Table 17)**

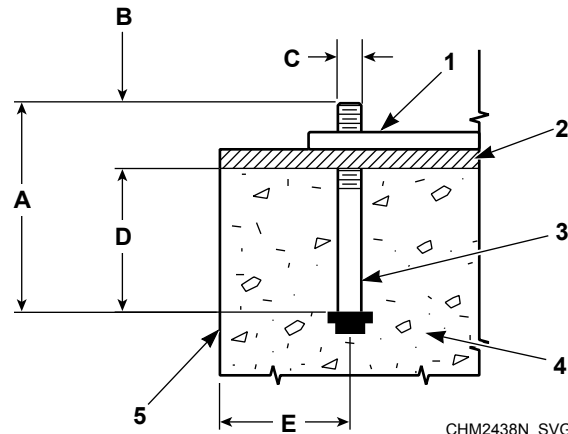

CHM2438N\_SVG

1. Machine Frame Base
2. Grout
3. Anchor Bolt (minimum Grade 5 SAE rating)
4. Concrete
5. Edge of Pad

Figure 16



<b>Minimum Anchoring Specifications, in. [mm]</b>		
<b>A</b>	Bolt Length	8-3/4 [22]
<b>B</b>	Thread Extension (minimum)	2-3/4 [70]
<b>C</b>	Bolt Diameter	3/4 [19]
<b>D</b>	Embedment Depth	6 [152]
<b>E</b>	Distance from Bolt Center to Edge of Concrete Pad	12 [305]

Table 17

# Mounting Bolt Pattern

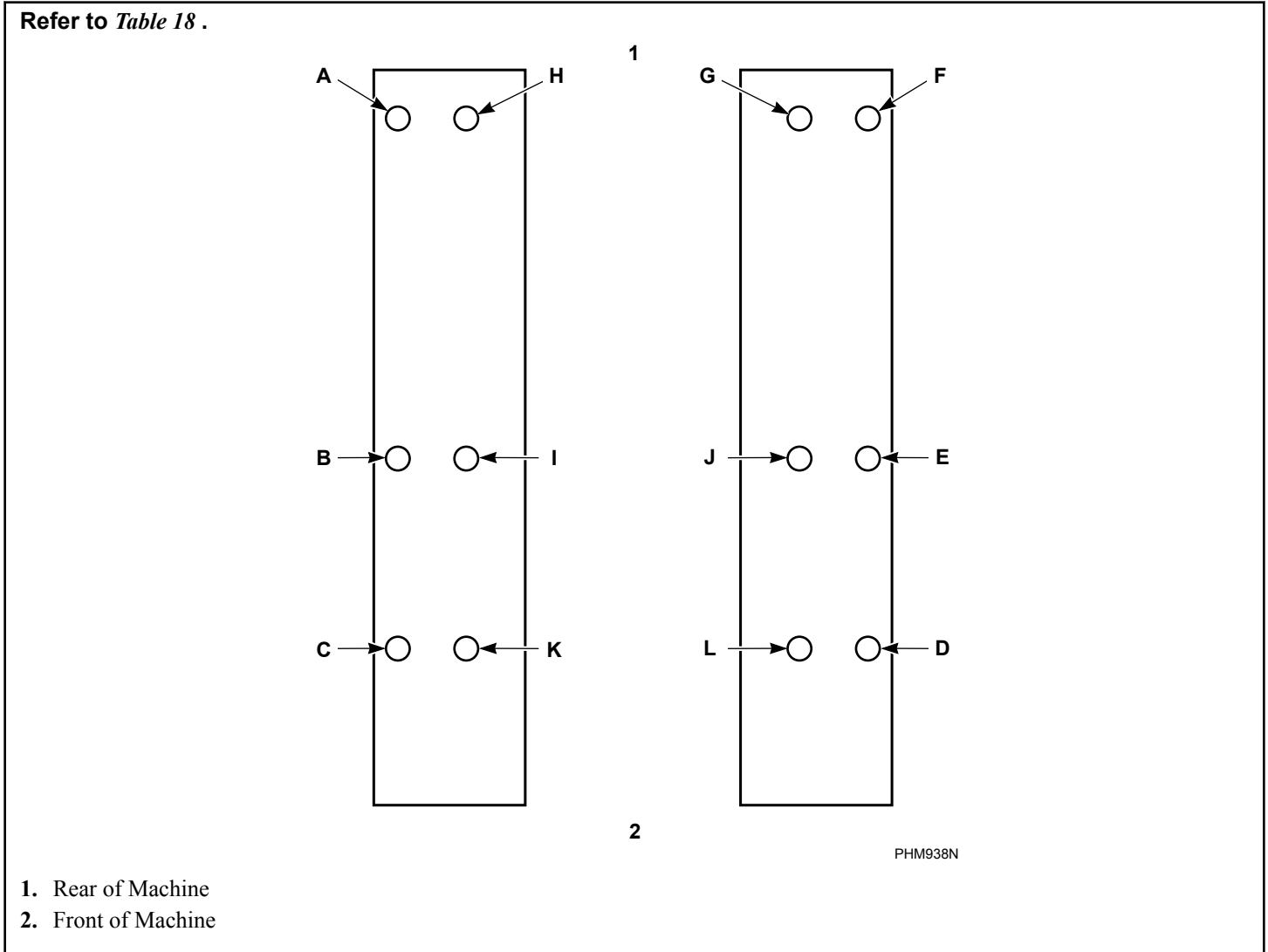

Figure 17

Models	Required Bolts	Optional Bolts*
45-65	A-F	G-L
85-105	A-H	I-L
130-200	A-J	K-L
* Use for further reduction of vibration.		

Table 18

## Floor Load Data

Floor Load Data								
Specifications		45	65	85	105	130	160	200
Static load, lb [kN]		1280 [5.7]	1350 [6.0]	1990 [8.9]	2100 [9.3]	2540 [11.3]	2680 [11.9]	2920 [13.0]
Static pressure, lb/ft <sup>2</sup> [kN/m <sup>2</sup> ]		158 [7.6]	167 [8.0]	170 [8.1]	179 [8.6]	178 [8.5]	187 [9.0]	204 [9.8]
Maximum dynamic load, lb [kN]		2690 [12]	2690 [12]	3300 [14.5]	3300 [14.5]	4200 [18.7]	4200 [18.7]	4200 [18.7]
Maximum dynamic pressure, lb/ft <sup>2</sup> [kN/m <sup>2</sup> ]	L-Speed	483 [23.1]	493 [23.6]	N/A	N/A	N/A	N/A	N/A
	M-Speed	483 [23.1]	493 [23.6]	446 [21.4]	457 [21.9]	469 [22.5]	N/A	497 [23.8]
	V-Speed	491 [23.5]	499 [23.9]	450 [21.5]	459 [22.0]	471 [22.6]	480 [23.0]	N/A
Dynamic load frequency, Hz	L-Speed	8.0	8.0	N/A	N/A	N/A	N/A	N/A
	M-Speed	11.2	11.2	9.9	9.9	9.7	N/A	9.7
	V-Speed	15.9	15.9	12.8	12.8	11.8	11.8	N/A
<sup>1</sup> Maximum vertical load,		3870 [17.2]	3940 [17.5]	5140 [22.9]	5210 [23.2]	6500 [28.9]	6590 [29.3]	6760 [30.1]
Maximum base moment, lb-ft [kN-m]		8470 [11.5]	8470 [11.5]	10700 [14.5]	10700 [14.5]	15000 [20.3]	15000 [20.3]	15000 [20.3]
<sup>1</sup> Acting in the downward direction against the floor.								

Table 19

## Drain Connection Requirements

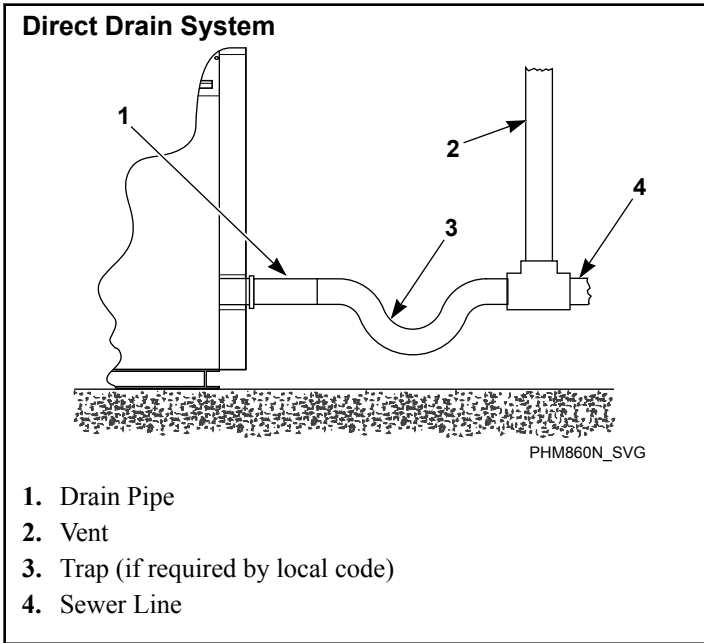

Figure 18

All drain systems must be vented to prevent an air lock and to prevent siphoning.

Refer to *Figure 18*.

**IMPORTANT: Machines must be installed in accordance with all local codes and ordinances.**

If proper drain size is not available or practical, a surge tank is required. A surge tank along with a sump pump should be used when gravity drainage is not possible.

Increasing the drain hose length, installing elbows, or causing bends will decrease drain flow rate and increase drain times, impairing machine performance.

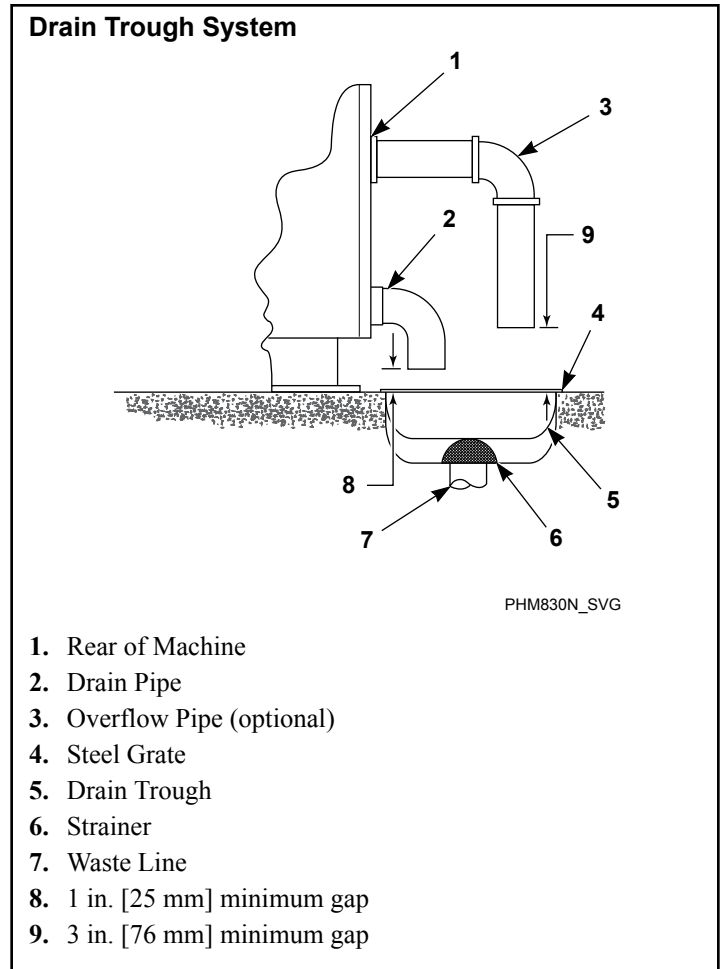

Figure 19

Refer to *Table 8* for capacity-specific drain information.

**NOTE: Installation of additional machines will require proportionately larger drain connections. Refer to *Table 8*.**

**IMPORTANT: Do not block the machine overflow opening.**

If water or suds flow from the machine overflow vent and the machine has been verified to be operating properly with proper water levels and correct amount of laundry chemicals, a drain line or an extension may be added to the machine overflow vent and routed to a drain trough.

1. To build a drain line, route the drain pipe from the machine overflow vent to a drain trough. As an option, the drain pipe can instead be routed straight across or down and be suspended above drain trough by at least 3 inches [76 mm].
2. To build an extension to the overflow vent, secure a section of drain pipe to the vent, facing upward, that extends no higher than the recommended height above the edge of the vent elbow. Refer to *Figure 20* and *Table 20*.
3. Secure the drain pipe with the hose clamp.

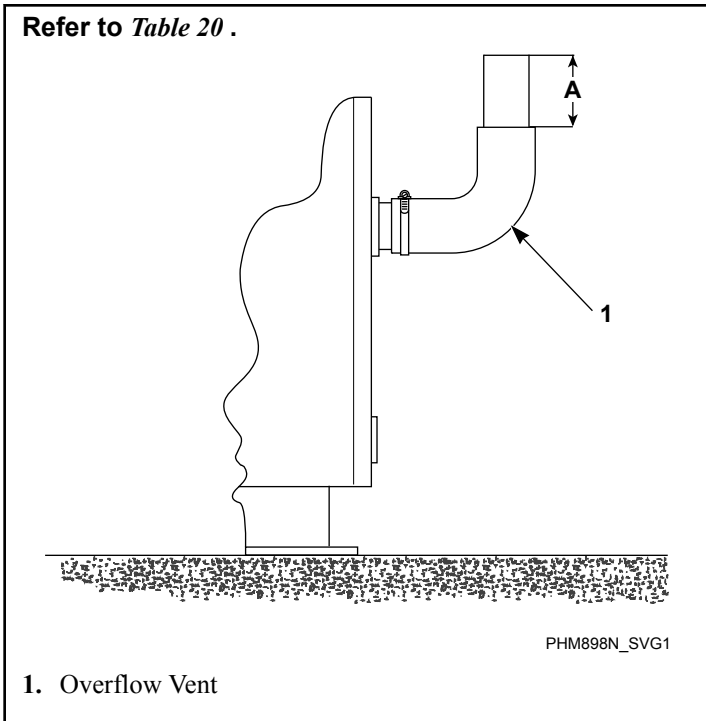

Figure 20

Vent Extension (maximum), in. [mm]			
	45-65	85-150	130-200
A	4 [102]	3-1/2 [89]	8-1/4 [210]

Table 20

**IMPORTANT: Do not route the machine overflow to a direct drain system.**

Drain Information						
Specifications	45	65	85	105	130	160-200
Drain connection size, in. with second drain	3	3	3	3	3	3
Number of drain outlets	UniLinc	1	1	2	2	2
	M30	1	1	1	1	N/A
Drain flow capacity, gal/min. [l/min.]	55 [208]	55 [208]	120 [454]	120 [454]	140 [530]	140 [530]
Max Drain Discharge (level 30), gal [l]	55	55	120	120	140	140
Recommended drain pit size, ft <sup>3</sup> [l]†	5 [142]	6 [170]	8 [227]	10 [283]	12 [340]	14.5 [411]

†Sized for one machine using overflow level.

Table 21

## Water Connection Requirements

Maximum water inlet temperature is 190 °Fahrenheit [ 88 °Celsius].

Connections should be supplied by hot and cold water lines of at least the sizes shown in the Water Supply Line Sizing table. Installation of additional machines will require proportionately larger water lines. Refer to *Table 23*.

		<b>WARNING</b>		
<p><b>To prevent personal injury, avoid contact with inlet water temperatures higher than 125° Fahrenheit [51° Celsius] and hot surfaces.</b></p> <p style="text-align: right;">W748</p>				
Water Supply Information				
Specifications		45-65	85-105	130-200
Number of water inlets	Main fill	2	2	2
	Spray rinse (Uni-Linc)	2	2	2
Water inlet connection size, in.	Main fill	3/4	3/4	1
	Spray rinse (Uni-Linc)	3/4	3/4	3/4
End of factory supplied hose	Size, in.	3/4	3/4	1
	Thread Pitch, GHT [BSPP]	3/4 x 11-1/2 [3/4 x 14]	3/4 x 11-1/2 [3/4 x 14]	1 x 11-1/2 [1 x 14]
Required pressure (min-max), psi [bar]		30-85 [2-5.7]	30-85 [2-5.7]	30-85 [2-5.7]
Inlet flow capacity for main fill (warm fill, both inlet valves open), gal/min at 85 psi [l/min at 1232 Pa]		45 [170]	47 [178]	54 [204]
Inlet flow capacity for spray rinse (warm fill, both inlet valves open), gal/min at 85 psi [l/min at 1232 Pa]		22 [83]	22 [83]	22 [83]

Table 22

To connect water service to machine with rubber hoses, use the following procedure:

1. Before installing hoses, flush the water system for at least two minutes.
2. Check filters in the machine's inlet hoses for proper fit and cleanliness before connecting.
3. Hang the hoses in a large loop; do not allow them to kink.

If additional hose lengths are needed or using hoses other than those supplied by manufacturer, flexible hoses with screen filters are required.

Lower pressures will increase fill times.

Suitable air cushions (risers) should be installed in supply lines to prevent "hammering." Refer to *Figure 21*.

Connect machine to a backflow preventer (vacuum breaker) before connecting to the public water main in all countries where local regulations require specific water approval certificates.

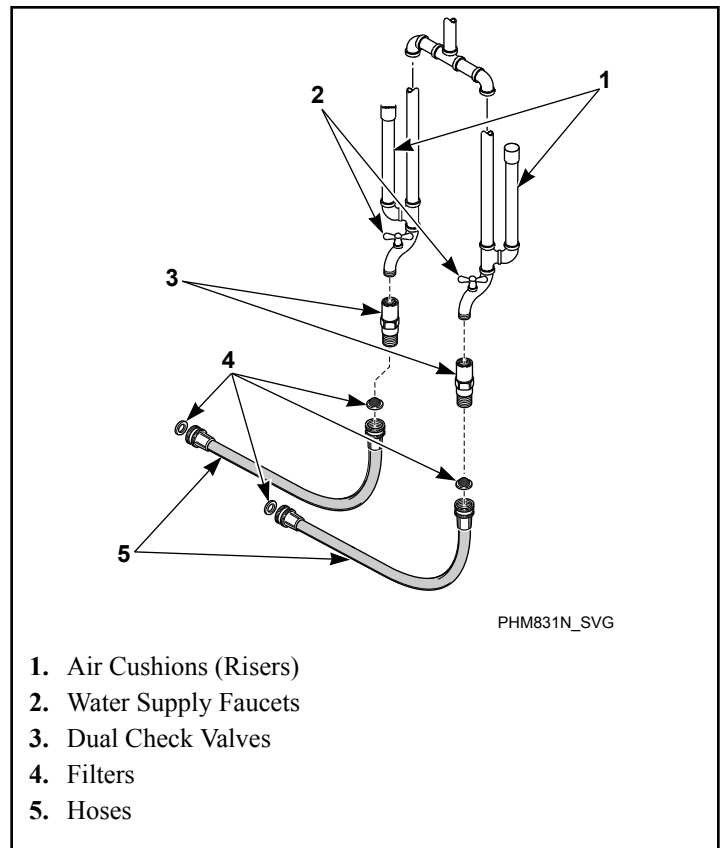

Figure 21

<b>Water Supply Line Sizing</b>			
<b>Models</b>	<b>Number of Machines</b>	<b>Supply Line Size, in.</b>	
		<b>Main</b>	<b>Hot/Cold</b>
<b>45-65</b>	1	1-1/4	1
	2	2	1-1/4
	3	2	1-1/2
	4	2-1/2	2
<b>85-105</b>	1	1-1/2	1
	2	2	1-1/2
	3	2-1/2	2
	4	3	2

Table 23 continues...

Water Supply Line Sizing			
Models	Number of Machines	Supply Line Size, in.	
		Main	Hot/Cold
130-200	1	2	1-1/4
	2	2-1/2	2
	3	3	2
	4	3-1/2	2-1/2

Table 23

### Connect Inlet Hoses

For laundries with four (4) supply faucets, use the following procedure to connect water service to a machine with hoses:

1. Before installing hoses, flush the building's water system at the machine connection valves for at least two (2) minutes.
2. Remove the four (4) plain rubber washers and four (4) filter screens from the accessories bag supplied with the machine.
3. Install one (1) plain rubber washer onto one end and one (1) filter screen into the other end of each fill hose. The screens must be facing outward toward the water supply. Refer to *Figure 22*.
4. Screw hose couplings with the filter screens onto the water supply faucets until they are finger-tight.
5. Using pliers, screw approximately 1/4 turn.
6. Screw the coupling with the plain rubber washer of one (1) of the hoses attached to a hot water connection onto the main fill valve inlet (marked "H", beneath the "F" mark). Screw the coupling with the plain rubber washer of the other hot water hose onto the spray valve inlet (marked "H", beneath the "S" mark). Tighten to finger-tight.
7. Screw the coupling with the plain rubber washer of one (1) of the hoses attached to a cold water connection onto the main fill valve inlet (marked "C", beneath the "F" mark). Screw the coupling with the plain rubber washer of the other cold water hose onto the spray valve inlet (marked "C", beneath the "S" mark). Tighten to finger-tight.
8. Using pliers, screw approximately 1/4 turn.
9. Hang hoses in a large loop; do not allow them to kink.
10. Turn on water supply and check for leaks.
11. If leaks are found, turn off the water, unscrew hoses and reinstall them until there are no leaks.

**IMPORTANT: DO NOT cross thread or overtighten couplings. This will cause them to leak.**

**IMPORTANT: Turn off water supply whenever there will be an extended period of non-use.**

If additional hose lengths are needed or using hoses other than those supplied by manufacturer, flexible hoses with screen filters are required.

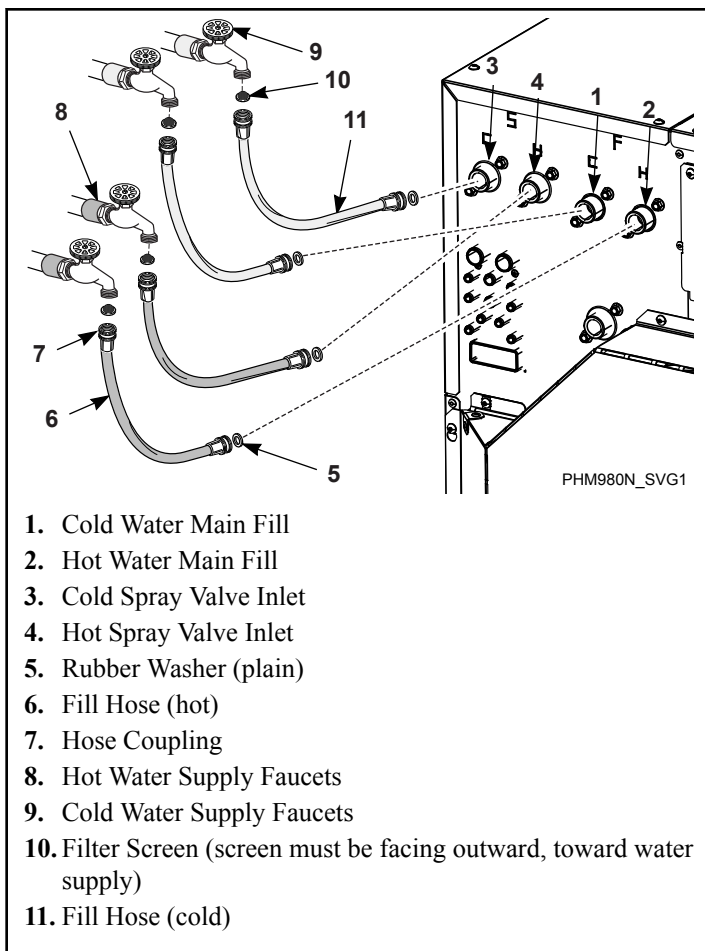

1. Cold Water Main Fill
2. Hot Water Main Fill
3. Cold Spray Valve Inlet
4. Hot Spray Valve Inlet
5. Rubber Washer (plain)
6. Fill Hose (hot)
7. Hose Coupling
8. Hot Water Supply Faucets
9. Cold Water Supply Faucets
10. Filter Screen (screen must be facing outward, toward water supply)
11. Fill Hose (cold)

Figure 22

### Connect Inlet Hoses with Y-Connectors

For laundries with two (2) supply faucets, use the following procedure to connect water service to a machine with hoses:



1. Before installing hoses, flush the building's water system at the machine connection valves for at least two (2) minutes.
2. Remove the four (4) plain rubber washers and four (4) filter screens from the accessories bag supplied with the machine.
3. Install one (1) plain rubber washer onto one end and one (1) filter screen into the other end of each fill hose. The screens must be facing outward toward the water supply. Refer to *Figure 23*.
4. Screw one (1) of the Y-connectors (supplied with the machine) into the cold water supply faucet and one (1) into the hot water supply faucet.
5. Screw hose couplings with the filter screens onto the water supply faucets until they are finger-tight.
6. Using pliers, screw approximately 1/4 turn.
7. Screw the coupling with the plain rubber washer of one (1) of the hoses attached to the hot water connection onto the main fill valve inlet (marked "H", beneath the "F" mark). Screw the coupling with the plain rubber washer of the other hot water hose onto the spray valve inlet (marked "H", beneath the "S" mark). Tighten to finger-tight. Refer to *Figure 23*.
8. Screw the coupling with the plain rubber washer of one (1) of the hose attached to the cold water connection onto the main fill valve inlet (marked "C", beneath the "F" mark). Screw the coupling with the plain rubber washer of the other cold water hose onto the spray valve inlet (marked "C", beneath the "S" mark). Tighten to finger-tight. Refer to *Figure 23*.
9. Using pliers, screw approximately 1/4 turn.

**IMPORTANT: DO NOT cross thread or overtighten couplings. This will cause them to leak.**

10. Hang hoses in a large loop; do not allow them to kink.
11. Turn on water supply and check for leaks.
12. If leaks are found, turn off the water, unscrew hoses and reinstall them until there are no leaks.

**IMPORTANT: Turn off water supply whenever there will be an extended period of non-use.**

If additional hose lengths are needed or using hoses other than those supplied by manufacturer, flexible hoses with screen filters are required.

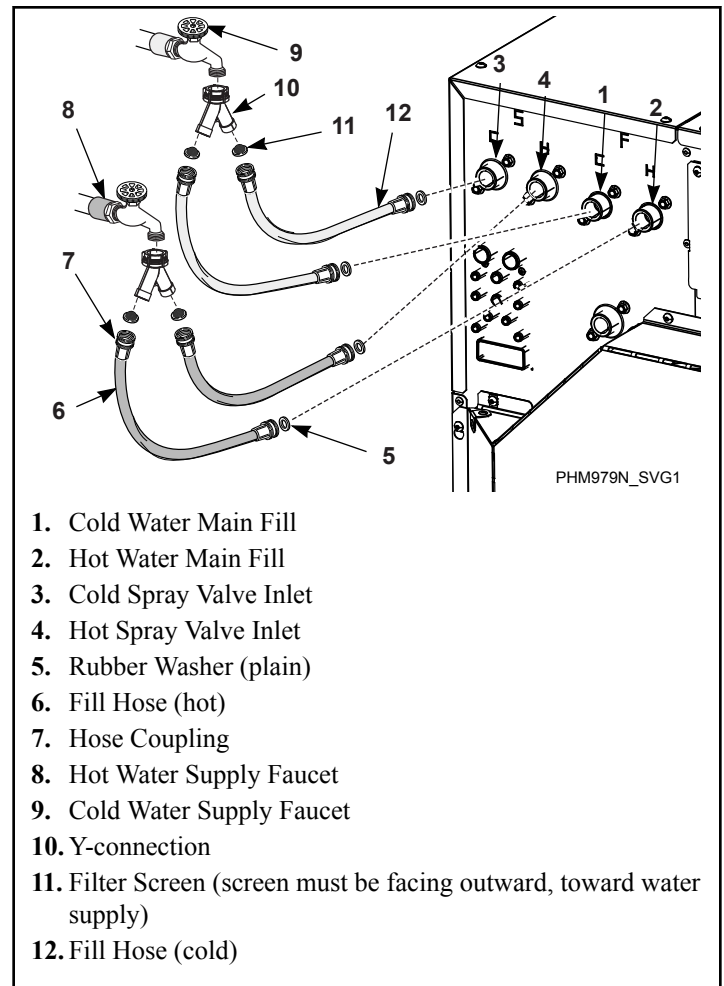

Figure 23

# Plumbing Diagrams

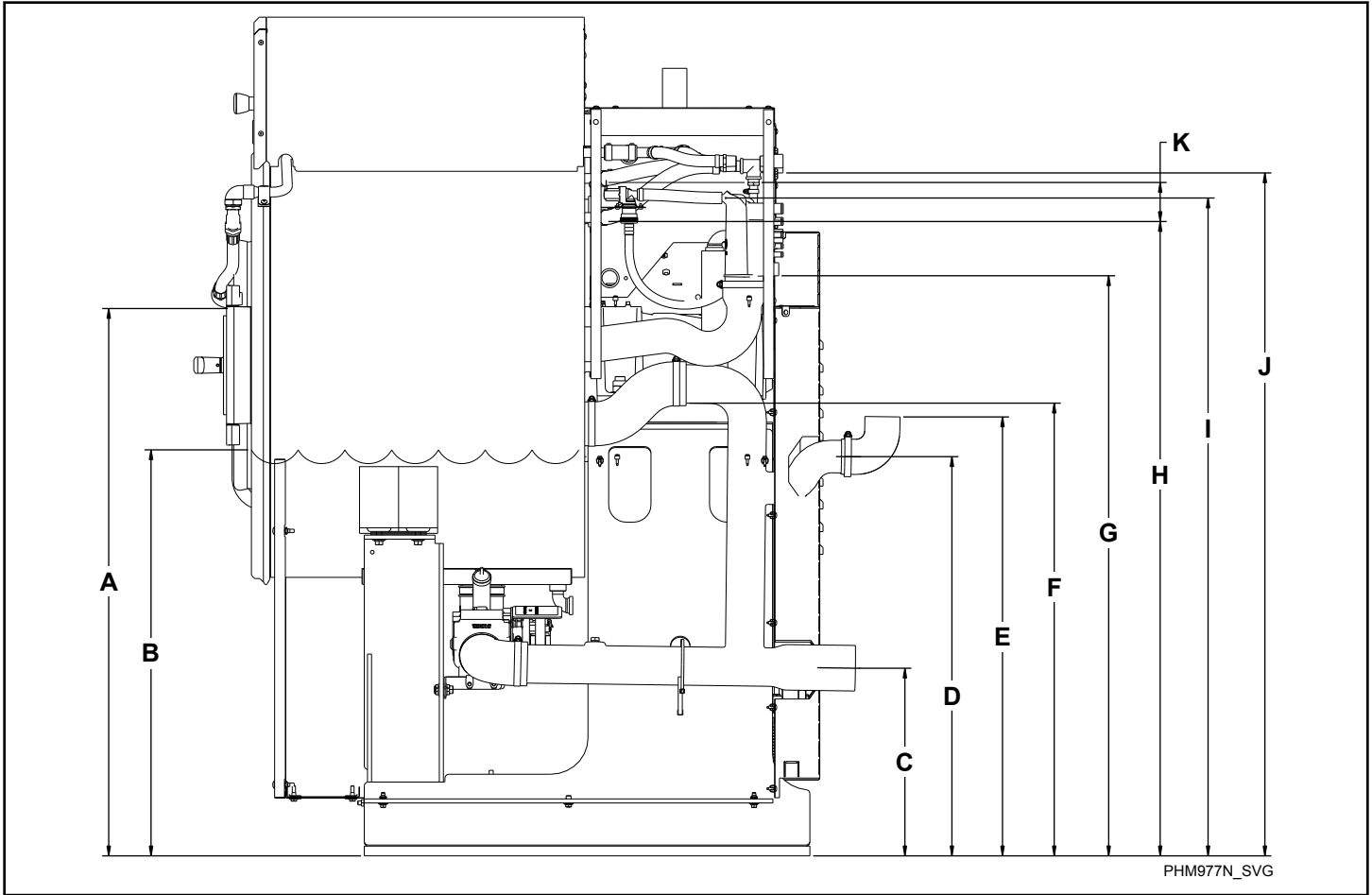

Figure 24

Plumbing Diagram - Chemical Injection, in. [mm]							
Description		45	65	85	105	130	160/200
A	Lowest point of door spray inlet (UniLine)	42.1 [1069]	42.1 [1069]	45 [1143]	45 [1143]	50.6 [1285]	50.6 [1285]
B	High fill water level	32.4 [823]	32.4 [823]	33.3 [846]	33.3 [846]	36 [914]	36 [914]
C	Center of drain outlet	14.2 [361]	14.2 [361]	12.2 [310]	12.2 [310]	12.2 [310]	12.2 [310]
D	Center of overflow outlet	30.5 [775]	30.5 [775]	30.7 [780]	30.7 [780]	29.5 [749]	29.5 [749]
E	Top of overflow outlet (optional)	33.5 [851]	33.5 [851]	34.2 [869]	34.2 [869]	32.9 [836]	32.9 [836]
F	Overflow spill	34.8 [884]	34.8 [884]	35.3 [897]	35.3 [897]	38.8 [986]	38.8 [986]
G	Chemical dispenser air gap	46.7 [1186]	46.7 [1186]	49.2 [1250]	49.2 [1250]	56.2 [1427]	56.2 [1427]

Table 24 continues...

<b>Plumbing Diagram - Chemical Injection, in. [mm]</b>							
<b>Description</b>		<b>45</b>	<b>65</b>	<b>85</b>	<b>105</b>	<b>130</b>	<b>160/200</b>
H	Main fill lower inlet port	48.7 [1237]	48.7 [1237]	52.3 [1328]	52.3 [1328]	57.7 [1466]	57.7 [1466]
I	Bottom of frame to Dispenser fill inlet	50.5 [1283]	50.5 [1283]	58.1 [1476]	58.1 [1476]	62.1 [1577]	62.1 [1577]
J	Bottom of frame to Inlet valve	52.6 [1336]	52.6 [1336]	57.5 [1461]	57.5 [1461]	64.5 [1638]	64.5 [1638]
K	Main fill lower inlet port Upper inlet port	3 [76]	3 [76]	3.02 [77]	3 [76]	3.6 [91]	3.6 [91]
	Maximum overflow	39.56 [1005]	39.56 [1005]	42.13 [1070]	42.13 [1070]	41.94 [1091]	41.94 [1091]

Table 24

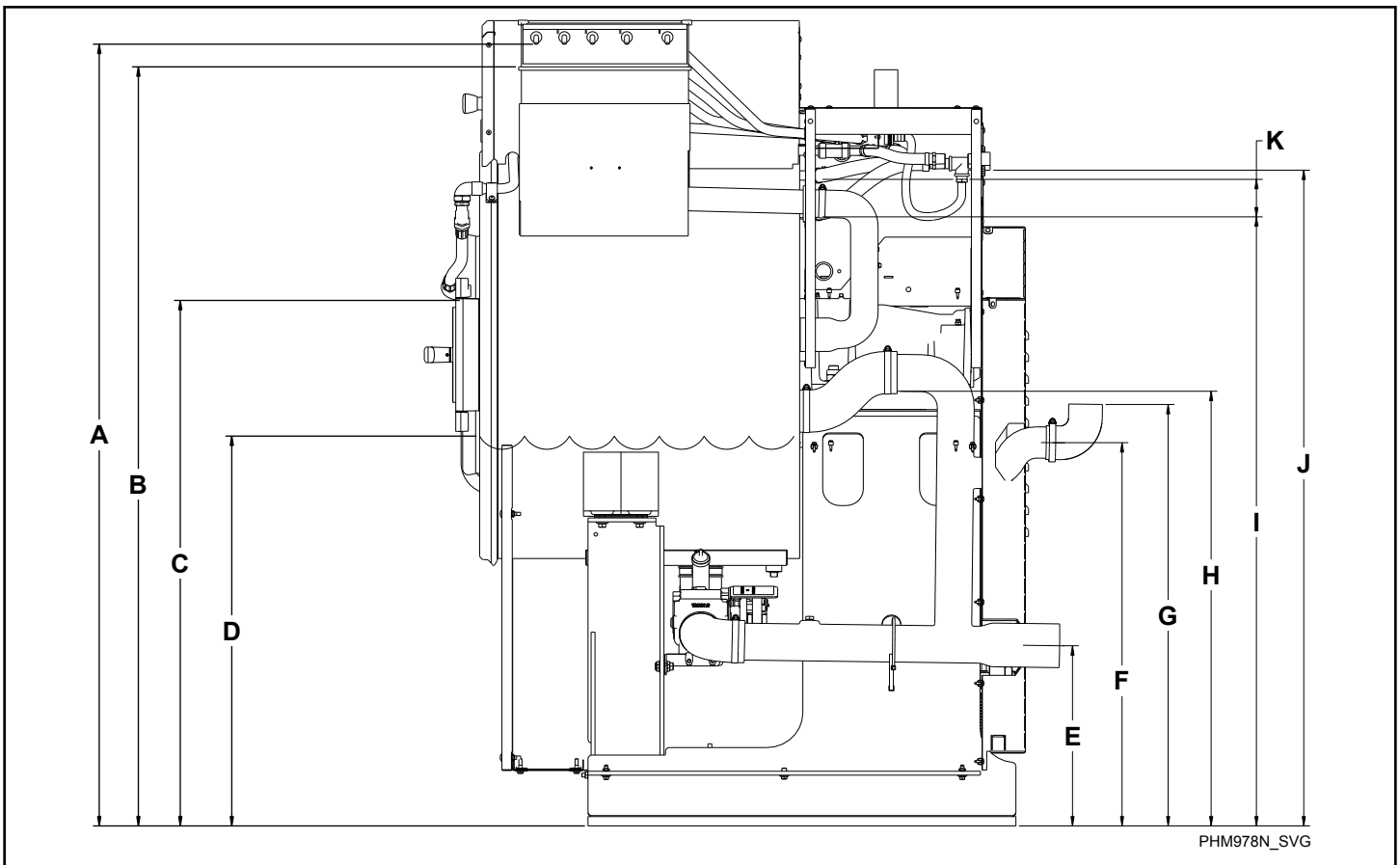

Figure 25

Plumbing Diagram - Five Compartment Supply Dispenser, in. [mm]							
Description		45	65	85	105	130	160/200
A	Dispenser inlet ports	62.6 [1590]	62.6 [1590]	65.6 [1666]	65.6 [1666]	70.5 [1791]	70.6 [1793]
B	Dispenser spill	60.7 [1542]	60.7 [1542]	63.6 [1615]	63.6 [1615]	68.9 [1750]	68.9 [1750]
C	Lowest point of door spray inlet (UniLinc)	42.1 [1069]	42.1 [1069]	45 [1143]	45 [1143]	50.6 [1285]	50.6 [1285]
D	High fill water level	32.4 [823]	32.4 [823]	33.3 [846]	33.3 [846]	36 [914]	36 [914]
E	Center of drain outlet	14.2 [361]	14.2 [361]	12.2 [310]	31.3 [795]	33.7 [856]	33.7 [856]
F	Center of overflow outlet	30.5 [775]	30.5 [775]	30.7 [780]	30.7 [780]	29.5 [749]	29.5 [749]
G	Top of overflow outlet (optional)	33.5 [851]	33.5 [851]	34.2 [869]	34.2 [869]	32.9 [836]	32.9 [836]
H	Overflow spill	34.8 [884]	34.8 [884]	35.3 [897]	35.2 [894]	38.8 [986]	38.8 [986]
I	Main fill lower inlet port	48.7 [1237]	48.7 [1237]	52.3 [1328]	52.3 [1328]	57.7 [1466]	57.8 [1468]

Table 25 continues...

Plumbing Diagram - Five Compartment Supply Dispenser, in. [mm]							
Description		45	65	85	105	130	160/200
J	Inlet valve	52.6 [1336]	52.6 [1336]	57.5 [1461]	57.5 [1461]	64.5 [1638]	64.5 [1638]
K	Upper inlet port	3 [76]	3 [76]	3 [76]	3 [76]	3.6 [91]	3.6 [91]
	Maximum overflow	39.56 [1005]	39.56 [1005]	42.13 [1070]	42.13 [1070]	41.94 [1065]	41.94 [1065]

Table 25

## Electrical Installation Requirements

**IMPORTANT:** Electrical ratings are subject to change. Refer to serial plate for electrical ratings information specific to your machine.

**NOTE:** For voltages above or below listed specification, a qualified electrical contractor must be consulted to install the appropriate transformer to meet the OEM electrical specifications. Refer to *Electrical Specifications (North American Approval)* and *Electrical Specifications (CE Approval)*.

	<b>DANGER</b>
<p><b>Electrical shock hazard will result in death or serious injury. Disconnect electric power and wait five (5) minutes before servicing.</b></p> <p style="text-align: right;">W810</p>	

Electrical connections are made at the rear of the machine. The machine must be connected to the proper electrical supply shown on the serial plate on the rear of the machine, using copper conductors only.

**IMPORTANT:** Alliance Laundry Systems warranty does not cover components that fail as a result of improper input voltage.

	<b>WARNING</b>
<p><b>Dangerous voltages are present inside the machine. Only qualified personnel should attempt adjustments and troubleshooting. Disconnect power from the machine before removing any cover and guards, and before attempting any service procedures.</b></p> <p style="text-align: right;">W736</p>	

Machines are equipped with an AC inverter drives requiring a clean power supply, free from voltage spikes and surges. Use voltage monitor to check incoming power.

	<b>WARNING</b>
<p><b>Hazardous Voltage. Can cause shock, burn or death. Verify that a ground wire from a proven earth ground is connected to the lug near the input power block on this machine.</b></p> <p style="text-align: right;">W360</p>	

	<b>WARNING</b>
<p><b>This Machine produces excessive leakage current. Do not use a grounding conductor smaller than 10mm<sup>2</sup>.</b></p> <p style="text-align: right;">W946</p>	

## Input Power Conditioning

The drive is suitable for direct connection to input power within the rated voltage of the drive. Listed in *Input Power Condition* are certain input power conditions which may cause component damage or reduction in product life. If any of the conditions exist,

install one of the devices listed under the Possible Corrective Action(s).

**IMPORTANT: Only one device per branch circuit is required. It should be mounted closest to the branch and sized to handle the total current of the branch circuit.**

Input Power Condition	Possible Corrective Action(s)
Low Line impedance (less than 1% line reactance)	<ul style="list-style-type: none"> <li>• Install Line Reactor</li> <li>• Isolation Transformer</li> </ul>
Greater than 120 kVA supply transformer	
Line has power factor correction capacitors	<ul style="list-style-type: none"> <li>• Install Line Reactor</li> <li>• Isolation Transformer</li> </ul>
Line has frequent power interruptions	
Line has intermittent noise spikes in excess of 3000V (lightning)	
Phase to ground voltage exceeds 125% of normal line to line voltage	<ul style="list-style-type: none"> <li>• Remove MOV jumper to ground</li> <li>• Install Isolation Transformer with grounded secondary (if necessary)</li> </ul>
Ungrounded distribution system	
240V open delta configuration (stinger leg)*	<ul style="list-style-type: none"> <li>• Install Line Reactor</li> </ul>
<p>* For drives applied on an open delta with a middle phase grounded neutral system, the phase opposite the phase that is tapped in the middle to the neutral or earth is referred to as the “stinger leg,” “high leg,” “red leg,” etc. This leg should be identified throughout the system with red or orange tape on the wire at each connection point. The stinger leg should be connected to the center Phase B on the reactor.</p>	

Table 26

## Input Voltage Requirements

For voltages above or below listed specifications, contact your power company or local electrician.

**IMPORTANT: Improper connections will result in equipment damage and will void warranty.**

	<b>DANGER</b>
<p><b>Electrical shock hazard will result in death or serious injury. Disconnect electric power and wait five (5) minutes before servicing.</b></p>	
W810	

## Circuit Breakers and Quick Disconnects

Single-phase machines require a single-phase inverse-time circuit breaker. Three-phase machines require a separate, three-phase inverse-time circuit breaker to prevent damage to the motor by disconnecting all legs if one should be lost accidentally. Refer to *North American Approval* and *CE Approval* sections for model-specific circuit breaker requirements.

**IMPORTANT: All quick disconnects should comply with the specifications. DO NOT use fuses instead of circuit breakers.**

## Connection Specifications

**IMPORTANT: Connection must be made by a qualified electrician using wiring diagram provided with machine, or according to accepted European Union standards.**

Connect machine to an individual branch circuit not shared with lighting or other equipment. Shield connection in a liquid-tight or approved flexible conduit. Copper conductors of correct size must be installed in accordance with National Electric Code (NEC) or other applicable codes.

Use wire sizes indicated in the Electrical Specifications chart for runs up to 50 feet [15 m]. Use next larger size for runs of 50 to 100 feet [15 to 30 m]. Use two (2) sizes larger for runs greater than 100 feet [30 m].

**IMPORTANT: For X voltage - To obtain 200-240V from a 200-240V source, connect L1 and L2. To obtain 220-240V from a 380-415V source, connect L1 and N. Refer to *Figure 26* .**

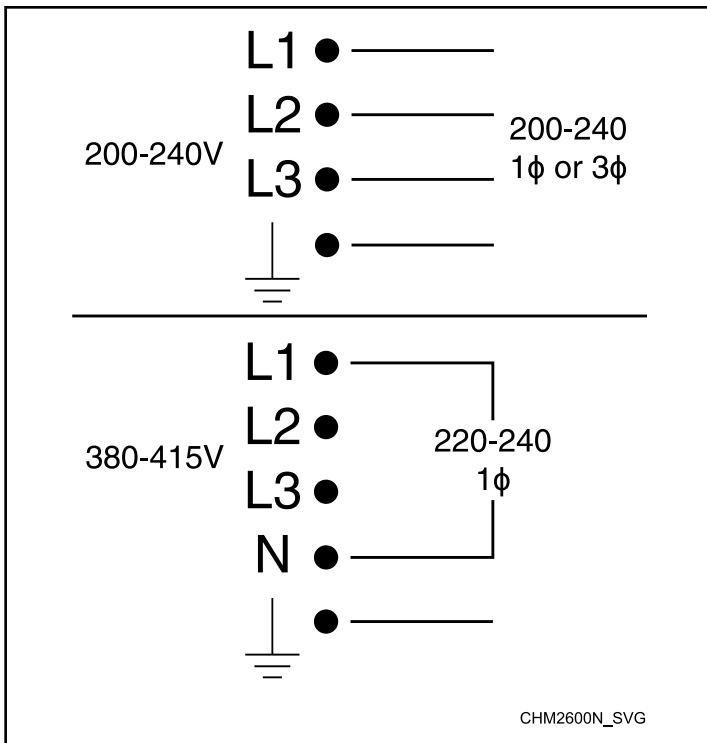

Figure 26

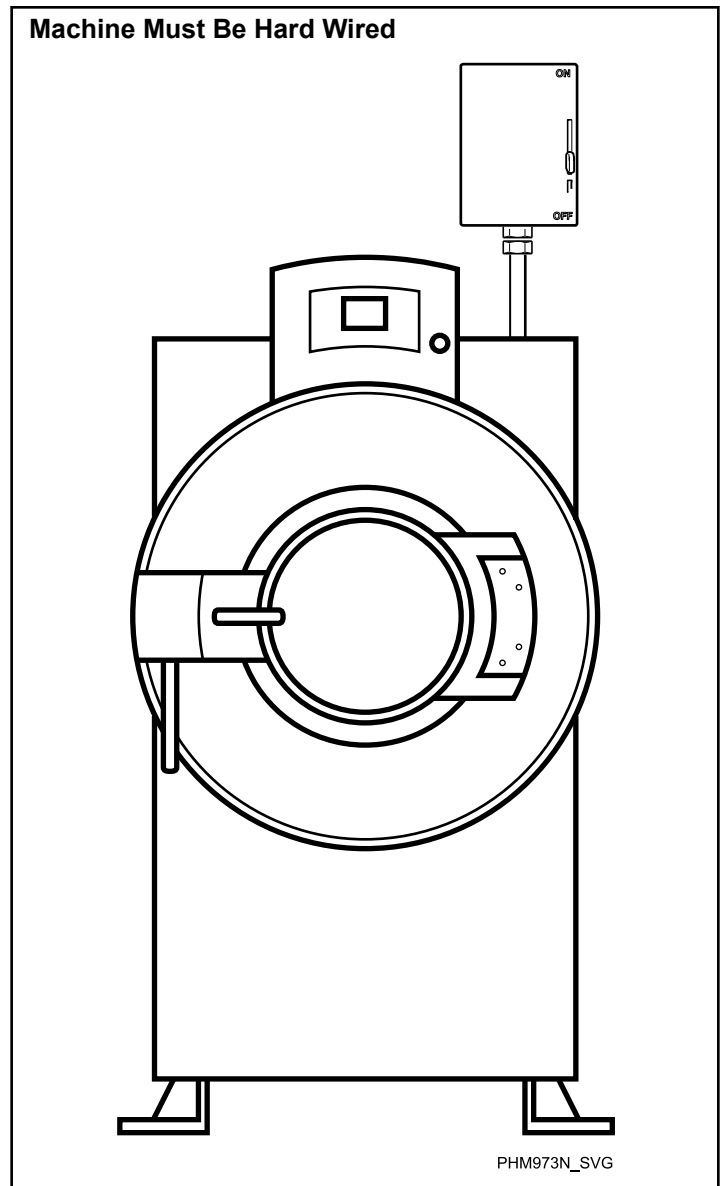

Figure 27

**NOTE:** Electrical receptacle must be located so that it is easily accessible with machine in place. An intermediate shut-off box with a 3 mm gap is required to meet EN 60335-1, clauses 24.3 and 22.2 or 3.5 mm gap is required to meet Standard IEC 60335-1, clauses 24.3 and 22.2. Gap is defined as the minimum contact separation of each pole in the switch between the “ON” and “OFF” positions.

### Single-Phase Connections

For single-phase input, connect L1, L2 and Ground and cap neutral as shown in *Figure 28*.

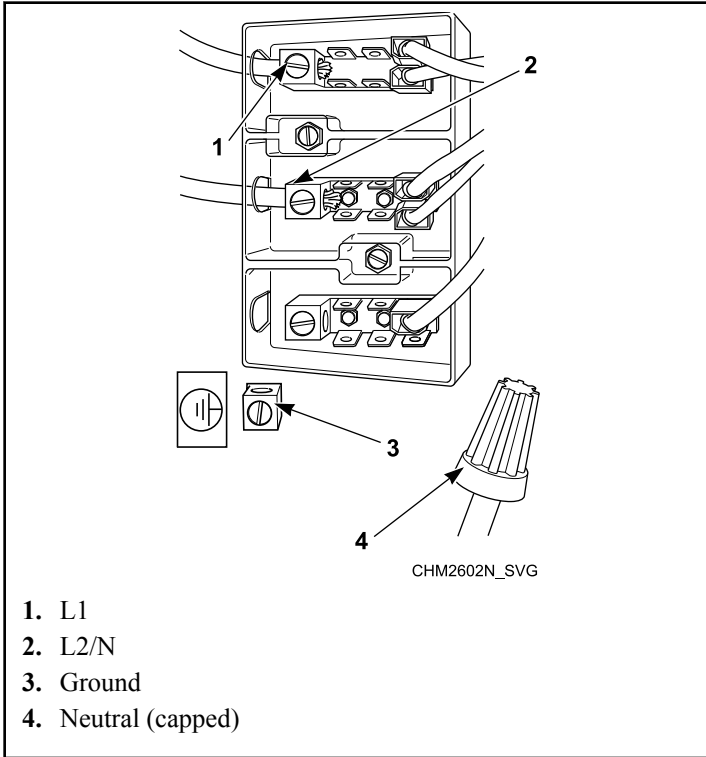

Figure 28

### Three-Phase Connections

For three-phase input, connect L1, L2, L3 and Ground as shown in *Figure 29*.

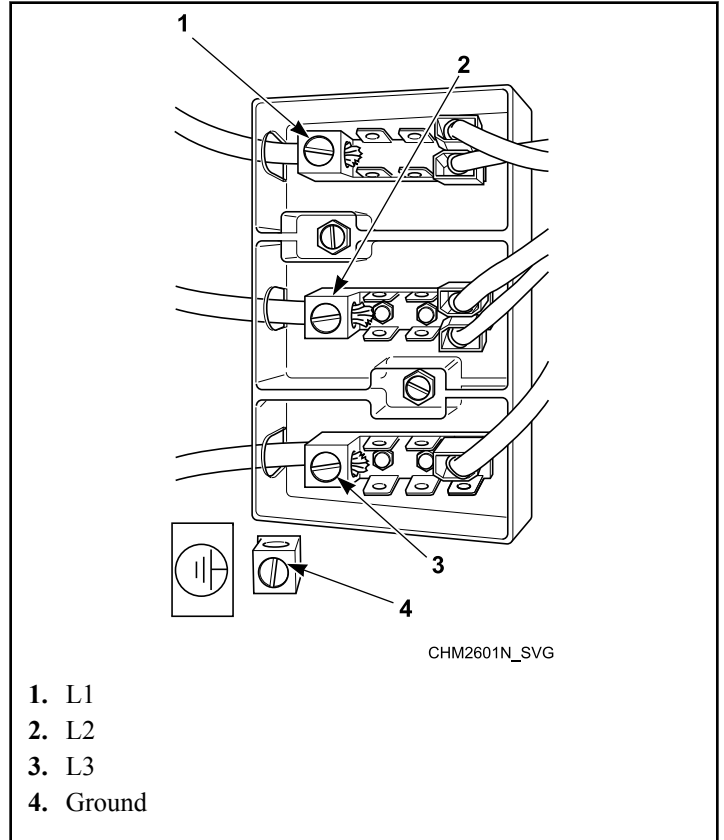



Figure 29

**IMPORTANT:** If a stinger leg is used for three-phase input, it **MUST** be connected to L3.

### Grounding

For personal safety and proper operation, the machine must be grounded in accordance with state and local codes. If such codes are not available, grounding must conform to the National Electric Code, article 250 (current edition). The ground connection must be made to a proven earth ground, not to conduit or water pipes.

	<b>WARNING</b>
<p><b>Electrically heated machines DO NOT require dual power sources. Do not connect customer power or customer load to the Internal Load Distribution terminal block. Refer to the machine electrical schematic for details.</b></p>	
W759	



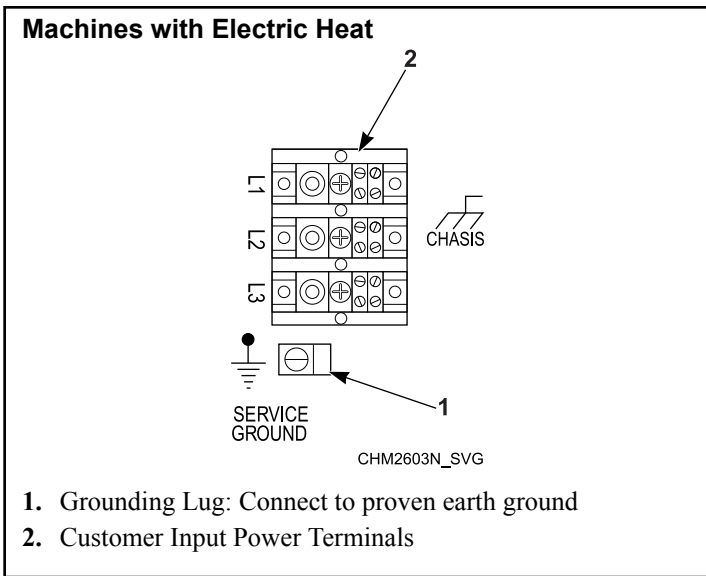

Figure 30

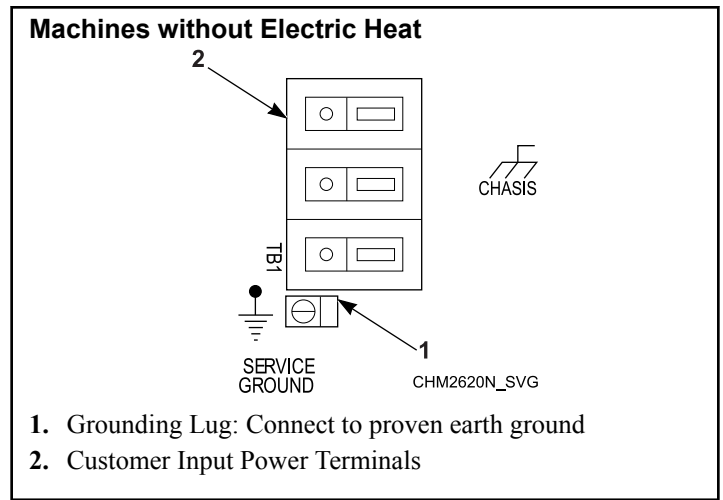

Figure 31

**Phase Adder**

**IMPORTANT: Do not use a phase adder on any machine.**

**Thermal Overload Protector**

The inverter drive provides overload protection for the drive motor.

### North American Approval

**NOTE: Wire sizing listed in this table is based on Article 310, Table 310.16 of the NEC; at 104°F [40°C] ambient temperature. Follow your local electrical codes. Use only copper conductors, rated for 194°F [90°C] or higher, type THHN or better. No more than three current carrying conductors per raceway. Contact your local Authority having jurisdiction if you have questions. Circuit breakers should be UL 489 listed or better. Single phase circuit breakers for single phase machines only; three phase circuit breakers for all others.**

45 Pound [20.4 Kg] Capacity Models - North American Approval									
Voltage Designation					Specifications				
Codes		Voltage	Cycle	Phase	Wire	Full Load Amps	Circuit Breaker	AWG	mm <sup>2</sup>
<b>L-Speed Models</b>									
X		200-240	50- 60	1/3	2/3	8/6	15	14	2.5
<b>M-Speed Models</b>									
X		200-240	50- 60	1/3	2/3	11/8	15	14	2.5
Q	Electric Heat	200-240	50- 60	3	3	71	80	4	25.0
N	Standard	440-480	50- 60	3	3	5	15	14	2.5
	Electric Heat					36	40	8	10.0
P	Standard	380-415	50- 60	3	3	5	15	14	2.5
	Electric Heat					32	40	8	10.0
<b>V-Speed Models</b>									
X		200-240	50- 60	1/3	2/3	16/ 10	20/ 15	12/ 14	4.0/ 2.5
Q	Electric Heat	200-240	50- 60	3	3	71	80	4	25.0
N	Standard	440-480	50- 60	3	3	7	15	14	2.5
	Electric Heat					36	40	8	10.0

Table 27 continues...

45 Pound [20.4 Kg] Capacity Models - North American Approval									
Voltage Designation					Specifications				
Codes		Voltage	Cycle	Phase	Wire	Full Load Amps	Circuit Breaker	AWG	mm <sup>2</sup>
P	Standard	380-415	50- 60	3	3	8	15	14	2.5
	Electric Heat					32	40	8	10.0

Table 27

65 Pound [29.5 Kg] Capacity Models - North American Approval									
Voltage Designation					Specifications				
Codes		Voltage	Cycle	Phase	Wire	Full Load Amps	Circuit Breaker	AWG	mm <sup>2</sup>
<b>L-Speed Models</b>									
X		200-240	50- 60	1/3	2/3	12/ 7	15	14	2.5
<b>M-Speed Models</b>									
X		200-240	50- 60	1/3	2/3	16/ 9	20/ 15	12/ 14	4.0/ 2.5
Q	Electric Heat	200-240	50- 60	3	3	71	80	4	25.0
N	Standard	440-480	50- 60	3	3	5	15	14	2.5
	Electric Heat					36	40	8	10.0
P	Standard	380-415	50- 60	3	3	5	15	14	2.5
	Electric Heat					32	40	8	10.0
<b>V-Speed Models</b>									
X		200-240	50- 60	1/3	2/3	16/ 10	20/ 15	12/ 14	4.0/ 2.5

Table 28 continues...

65 Pound [29.5 Kg] Capacity Models - North American Approval									
Voltage Designation					Specifications				
Codes		Voltage	Cycle	Phase	Wire	Full Load Amps	Circuit Breaker	AWG	mm <sup>2</sup>
Q	Electric Heat	200-240	50- 60	3	3	71	80	4	25.0
N	Standard	440-480	50- 60	3	3	7	15	14	2.5
	Electric Heat					36	40	8	10.0
P	Standard	380-415	50- 60	3	3	8	15	14	2.5
	Electric Heat					32	40	8	10.0

Table 28

85 Pound [38.6 Kg] Capacity Models - North American Approval									
Voltage Designation					Specifications				
Codes		Voltage	Cycle	Phase	Wire	Full Load Amps	Circuit Breaker	AWG	mm <sup>2</sup>
<b>M-Speed Models</b>									
Q	Standard	200-240	50- 60	3	3	14	20	12	4
	Electric Heat					105	110	2	35
N	Standard	440-480	50- 60	3	3	9	15	14	2.5
	Electric Heat					39	40	8	10
P	Standard	380-415	50- 60	3	3	9	15	14	2.5
	Electric Heat					35	40	8	10
<b>V-Speed Models</b>									

Table 29 continues...

85 Pound [38.6 Kg] Capacity Models - North American Approval									
Voltage Designation					Specifications				
Codes		Voltage	Cycle	Phase	Wire	Full Load Amps	Circuit Breaker	AWG	mm <sup>2</sup>
Q	Standard	200-240	50- 60	3	3	16	20	12	4
	Electric Heat					105	110	2	35
N	Standard	440-480	50- 60	3	3	10	15	14	2.5
	Electric Heat					39	40	8	10
P	Standard	380-415	50- 60	3	3	10	15	14	2.5
	Electric Heat					35	40	8	10

Table 29

105 Pound [47.6 Kg] Capacity Models - North American Approval									
Voltage Designation					Specifications				
Codes		Voltage	Cycle	Phase	Wire	Full Load Amps	Circuit Breaker	AWG	mm <sup>2</sup>
<b>M-Speed Models</b>									
Q	Standard	200-240	50- 60	3	3	14	20	12	4
	Electric Heat					108	110	2	35
N	Standard	440-480	50- 60	3	3	9	15	14	2.5
	Electric Heat					40	50	8	10
P	Standard	380-415	50- 60	3	3	9	15	14	2.5
	Electric Heat					36	40	8	10

Table 30 continues...

105 Pound [47.6 Kg] Capacity Models - North American Approval									
Voltage Designation					Specifications				
Codes		Voltage	Cycle	Phase	Wire	Full Load Amps	Circuit Breaker	AWG	mm <sup>2</sup>
<b>V-Speed Models</b>									
Q	Standard	200-240	50- 60	3	3	16	20	12	4
	Electric Heat					108	110	2	35
N	Standard	440-480	50- 60	3	3	10	15	14	2.5
	Electric Heat					40	50	8	10
P	Standard	380-415	50- 60	3	3	10	15	14	2.5
	Electric Heat					36	40	8	10

Table 30

130 Pound [59 Kg] Capacity Models - North American Approval									
Voltage Designation					Specifications				
Codes		Voltage	Cycle	Phase	Wire	Full Load Amps	Circuit Breaker	AWG	mm <sup>2</sup>
<b>M-Speed Models</b>									
Q	Standard	200-240	50- 60	3	3	16	20	12	4
N	Standard	440-480	50- 60	3	3	10	15	14	2.5
	Electric Heat					74	80	4	25
P	Standard	380-415	50- 60	3	3	10	15	14	2.5
	Electric Heat					65	70	4	25

Table 31 continues...

130 Pound [59 Kg] Capacity Models - North American Approval									
Voltage Designation					Specifications				
Codes		Voltage	Cycle	Phase	Wire	Full Load Amps	Circuit Breaker	AWG	mm <sup>2</sup>
<b>V-Speed Models</b>									
Q	Standard	200-240	50- 60	3	3	21	30	10	6
N	Standard	440-480	50- 60	3	3	12	15	14	2.5
	Electric Heat					74	80	4	25
P	Standard	380-415	50- 60	3	3	12	15	14	2.5
	Electric Heat					65	70	4	25

Table 31

160 Pound [72.6 Kg] Capacity Models - North American Approval									
Voltage Designation					Specifications				
Codes		Voltage	Cycle	Phase	Wire	Full Load Amps	Circuit Breaker	AWG	mm <sup>2</sup>
<b>V-Speed Models</b>									
Q	Standard	200-240	50- 60	3	3	22	30	10	6
N	Standard	440-480	50- 60	3	3	12	15	14	2.5
	Electric Heat					74	80	4	25
P	Standard	380-415	50- 60	3	3	12	15	14	2.5
	Electric Heat					65	70	4	25

Table 32

200 Pound [90.7 Kg] Capacity Models - North American Approval									
Voltage Designation					Specifications				
Codes		Voltage	Cycle	Phase	Wire	Full Load Amps	Circuit Breaker	AWG	mm <sup>2</sup>
<b>M-Speed Models</b>									
Q	Standard	200-240	50- 60	3	3	22	30	10	6
N	Standard	440-480	50- 60	3	3	12	15	14	2.5
	Electric Heat					74	80	4	25
P	Standard	380-415	50- 60	3	3	12	15	14	2.5
	Electric Heat					65	70	4	25

Table 33



**CE Approval**

**NOTE:** Wire sizing listed in this table is based on Article 310, Table 310.16 of the NEC; at 104°F [40°C] ambient temperature. Follow your local electrical codes. Use only copper conductors, rated for 194°F [90°C] or higher, type THHN or better. No more than three current carrying conductors per raceway. Contact your local Authority having jurisdiction if you have questions. Circuit breakers should be UL 489 listed or better. Single phase circuit breakers for single phase machines only; three phase circuit breakers for all others.

**NOTE:** N and P Voltage - Where the protective conductor has a cross-sectional area of less than 10 mm<sup>2</sup> Cu, a second protective conductor of at least the same cross-sectional area shall be provided up to a point where the protective conductor has a cross-sectional area not less than 10 mm<sup>2</sup> Cu.

45 Pound [20.4 Kg] Capacity Models - CE Approval								
Voltage Designation					Specifications			
Code		Voltage	Cycle	Phase	Wire	Full Load Amps	Circuit Breaker	mm <sup>2</sup>
<b>L-Speed Models</b>								
X		200-240	50-60	1/3	2/3	11/7	16/ 10	2.5
<b>M-Speed Models</b>								
X		200-240	50-60	1/3	2/3	11/8	16/ 10	2.5
Q	Electric Heat	200-240	50-60	3	3	59-70	80	16
N	Standard	440-480	50-60	3	3	5	6	2.5
	Electric Heat					35	40	4
P	Standard	380-415	50-60	3	3	5	6	2.5
	Electric Heat					30	40	4
<b>V-Speed Models</b>								
X		200-240	50-60	1/3	2/3	17/11	20/ 16	2.5
Q	Electric Heat	200-240	50-60	3	3	59-70	80	16
N	Standard	440-480	50-60	3	3	7	10	2.5
	Electric Heat					35	40	4
P	Standard	380-415	50-60	3	3	8	10	2.5
	Electric Heat					30	40	4

Table 34

65 Pound [29.5 Kg] Capacity Models - CE Approval								
Voltage Designation					Specifications			
Code		Voltage	Cycle	Phase	Wire	Full Load Amps	Circuit Breaker	mm <sup>2</sup>
<b>L-Speed Models</b>								
X		200-240	50-60	1/3	2/3	12/7	16/ 10	2.5
<b>M-Speed Models</b>								
X		200-240	50-60	1/3	2/3	17/9	20/ 10	2.5
Q	Electric Heat	200-240	50-60	3	3	59-70	80	16
N	Standard	440-480	50-60	3	3	5	6	2.5
	Electric Heat					35	40	4
P	Standard	380-415	50-60	3	3	5	6	2.5
	Electric Heat					30	40	4
<b>V-Speed Models</b>								
X		200-240	50-60	1/3	2/3	17/11	20/ 16	2.5
Q	Electric Heat	200-240	50-60	3	3	59-70	80	16
N	Standard	440-480	50-60	3	3	7	10	2.5
	Electric Heat					35	40	4
P	Standard	380-415	50-60	3	3	8	10	2.5
	Electric Heat					30	40	4

Table 35

85 Pound [38.6 Kg] Capacity Models - CE Approval								
Voltage Designation					Specifications			
Code		Voltage	Cycle	Phase	Wire	Full Load Amps	Circuit Breaker	mm <sup>2</sup>
<b>M and V-Speed Models</b>								
Q	Standard	200-240	50-60	3	3	17	20	2.5
	Electric Heat					87- 103	125	35
N	Standard	440-480	50-60	3	3	11	16	2.5
	Electric Heat					35	40	4
P	Standard	380-415	50-60	3	3	11	16	2.5
	Electric Heat					30	40	4

Table 36

105 Pound [47.6 Kg] Capacity Models - CE Approval								
Voltage Designation					Specifications			
Code		Voltage	Cycle	Phase	Wire	Full Load Amps	Circuit Breaker	mm <sup>2</sup>
<b>M and V-Speed Models</b>								
Q	Standard	200-240	50-60	3	3	17	20	2.5
	Electric Heat					67- 103	125	35
N	Standard	440-480	50-60	3	3	11	16	2.5
	Electric Heat					35	40	4
P	Standard	380-415	50-60	3	3	11	16	2.5
	Electric Heat					30	40	4

Table 37

130 Pound [59 Kg] Capacity Models - CE Approval								
Voltage Designation					Specifications			
Code		Voltage	Cycle	Phase	Wire	Full Load Amps	Circuit Breaker	mm <sup>2</sup>
<b>M-Speed Models</b>								
Q	Standard	200-240	50-60	3	3	17	20	2.5
N	Standard	440-480	50-60	3	3	11	16	2.5
	Electric Heat					70	80	16
P	Standard	380-415	50-60	3	3	11	16	2.5
	Electric Heat					61	80	16
<b>V-Speed Models</b>								
Q		200-240	50-60	3	3	21	25	2.5
N	Standard	440-480	50-60	3	3	12	16	2.5
	Electric Heat					70	80	16
P	Standard	380-415	50-60	3	3	12	16	2.5
	Electric Heat					61	80	16

Table 38

160 Pound [72.6 Kg] Capacity Models - CE Approval								
Voltage Designation					Specifications			
Code		Voltage	Cycle	Phase	Wire	Full Load Amps	Circuit Breaker	mm <sup>2</sup>
<b>V-Speed Models</b>								
Q	Standard	200-240	50-60	3	3	22	25	2.5
N	Standard	440-480	50-60	3	3	12	16	2.5
	Electric Heat					70	80	16

Table 39 continues...

160 Pound [72.6 Kg] Capacity Models - CE Approval								
Voltage Designation					Specifications			
Code		Voltage	Cycle	Phase	Wire	Full Load Amps	Circuit Breaker	mm <sup>2</sup>
P	Standard	380-415	50-60	3	3	12	16	2.5
	Electric Heat					61	80	16

Table 39

200 Pound [90.7 Kg] Capacity Models - CE Approval								
Voltage Designation					Specifications			
Code		Voltage	Cycle	Phase	Wire	Full Load Amps	Circuit Breaker	mm <sup>2</sup>
<b>M-Speed Models</b>								
Q	Standard	200- 240	50-60	3	3	22	25	2.5
N	Standard	440- 480	50-60	3	3	12	16	2.5
	Electric Heat					70	80	16
P	Standard	380- 415	50-60	3	3	12	16	2.5
	Electric Heat					61	80	16

Table 40

### Steam Requirements (Steam Heat Option Only)

For machines equipped with optional steam heat, install piping in accordance with approved commercial steam practices. Steam requirements are shown in *Table 1*.

	<b>WARNING</b>
<p><b>Hot Surfaces. Will cause severe burns. Turn steam off and allow steam pipes, connections and components to cool before touching.</b></p>	
W505	

# Chemical Injection Supply System

	<b>WARNING</b>
<p><b>Dangerous Chemicals. May damage eyes and skin. Wear eye and hand protection when handling chemicals; always avoid direct contact with raw chemicals. Read the manufacturer's directions for accidental contact before handling chemicals. Ensure an eye-rinse facility and an emergency shower are within easy reach. Check at regular intervals for chemical leaks.</b></p>	
W363	

**IMPORTANT:** Undiluted chemical dripping can damage the machine. All chemical injection supply dispenser pumps and dispenser tubing should be mounted below the washer's injection point. Loops do not prevent drips if these instructions are not followed. *Figure 34* shows a typical Chemical Injection Supply System. *Figure 35* shows a typical Five Compartment Supply System.

**IMPORTANT:** Failure to follow these instructions could damage the machine and void the warranty.

The chemical supply connector is located on the back right-hand side of the machine. There are 12 chemical ports on the connector, through each a liquid supply hose can be connected.

**IMPORTANT:** Water pressure must not exceed 40 psi [275 kPa].

1. Drill through the ports on the chemical supply connector as needed for the external supply hoses.

**NOTE:** 3/8 inch ports must be drilled through with a 3/16 inch diameter drill bit and 1/2 inch ports must be drilled through with a 5/16 inch diameter drill bit before connecting chemical lines. Refer to *Figure 33*.

**IMPORTANT:** Be careful to only drill through the first wall so as not to damage the machine.

2. Remove plastic debris.
3. Attach the external supply hoses to the ports at each of the drilled holes.
4. Secure with proper clamps.

	<b>CAUTION</b>
<p><b>Drill out plugs and nipples before making supply hose connection. Failure to do so can cause buildup of pressure and risk a tubing rupture.</b></p>	
W491	

Supply Dispensing	
Number of liquid chemical supply signals (if equipped)	4 or 8
Number of supply compartments	5
Number of external liquid supply connections	12

Table 41

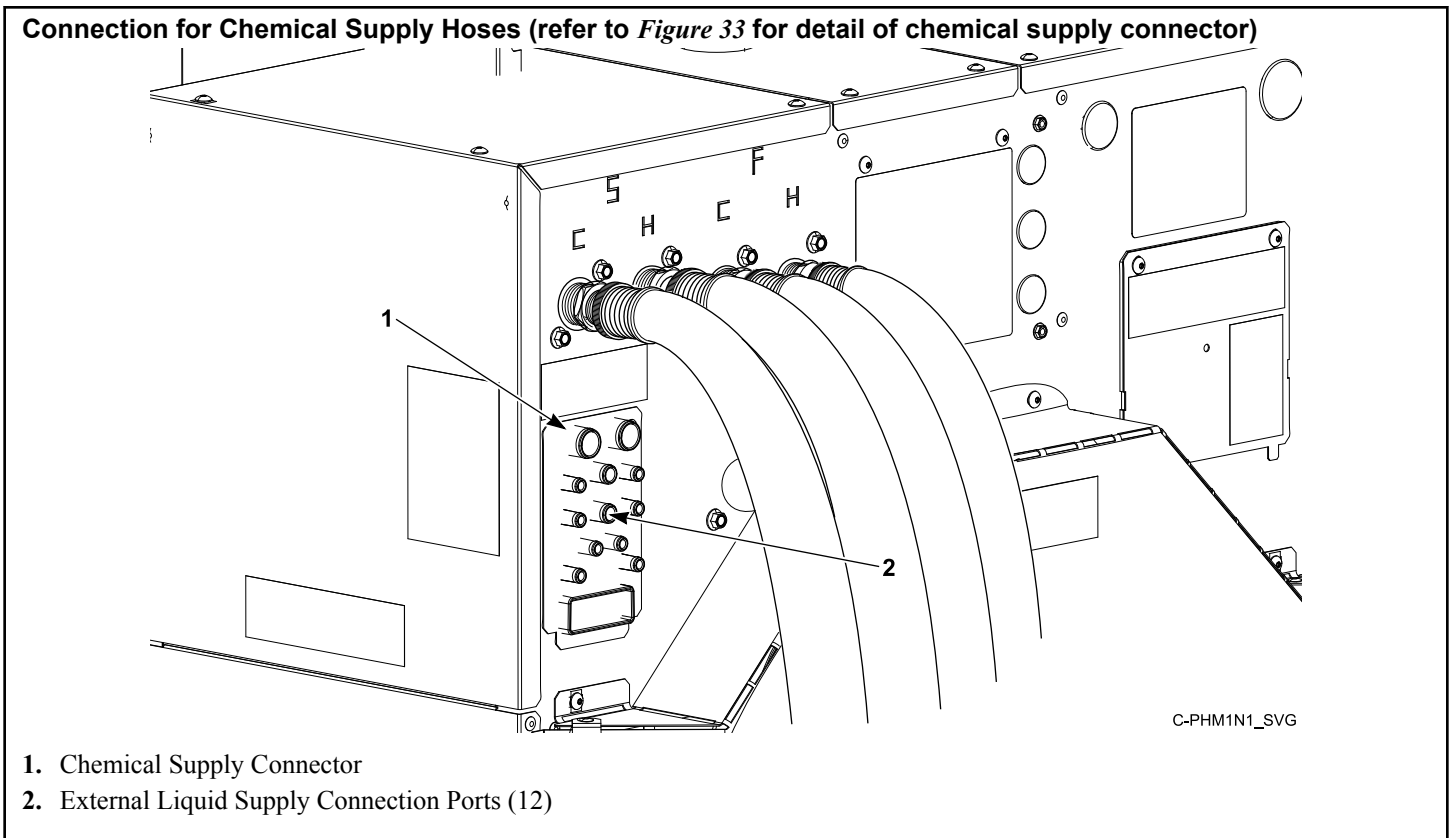
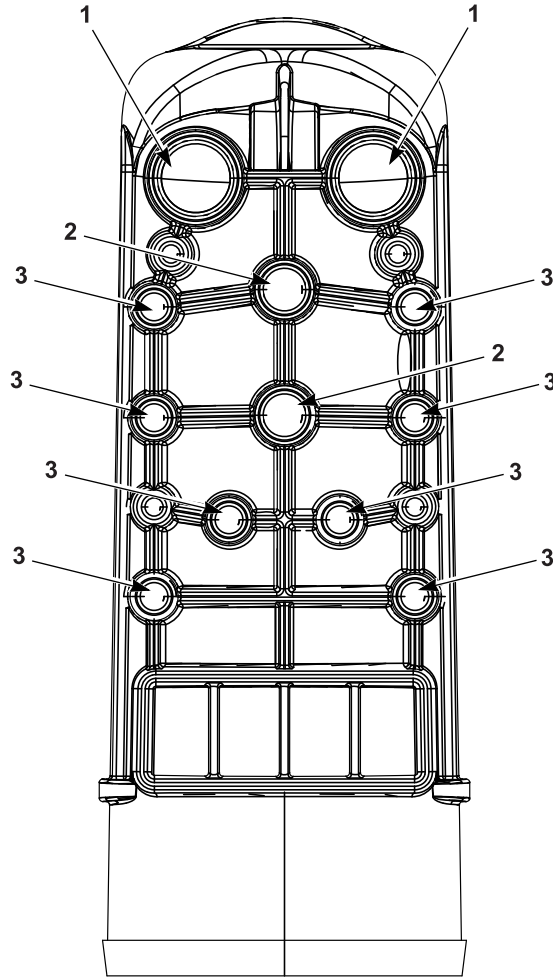

Figure 32

### External Liquid Supply Connection Ports



C-PHM2N2\_SVG1

- 1. 3/4 inch port, O.D.
- 2. 1/2 inch port, O.D.
- 3. 3/8 inch port, O.D.

Figure 33



**Chemical Supply Setup**

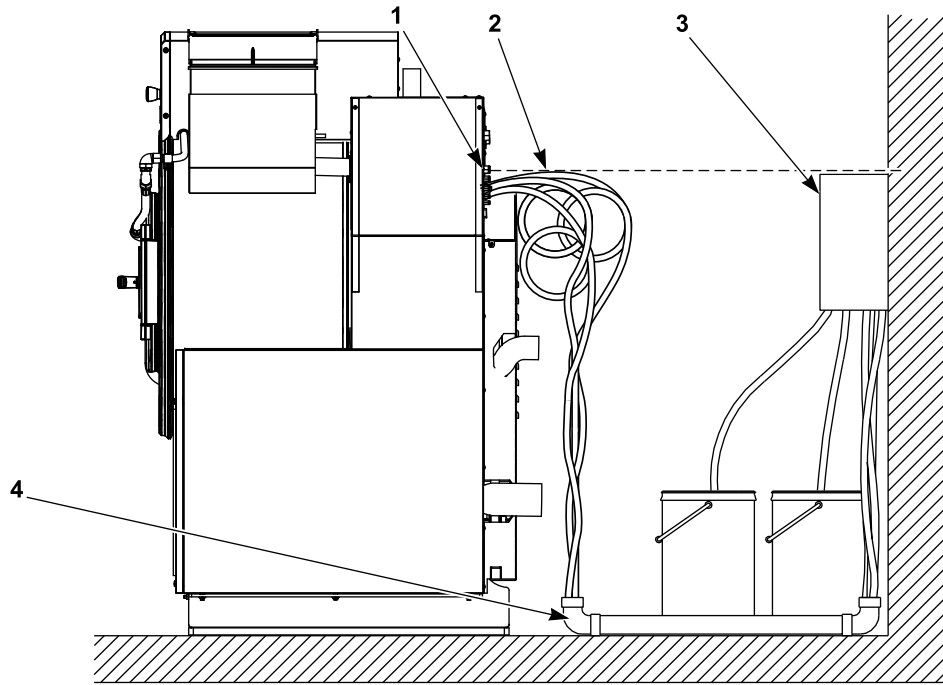

PHM974N\_SVG1

\* Use a check valve on the end of tubing

† Pumps must be mounted below the injection point

- 1. Injection Point\*
- 2. Loops
- 3. Chemical Dispenser Pump Outlet †
- 4. PVC Pipe

Figure 34

## Five Compartment Supply Dispenser (Optional)

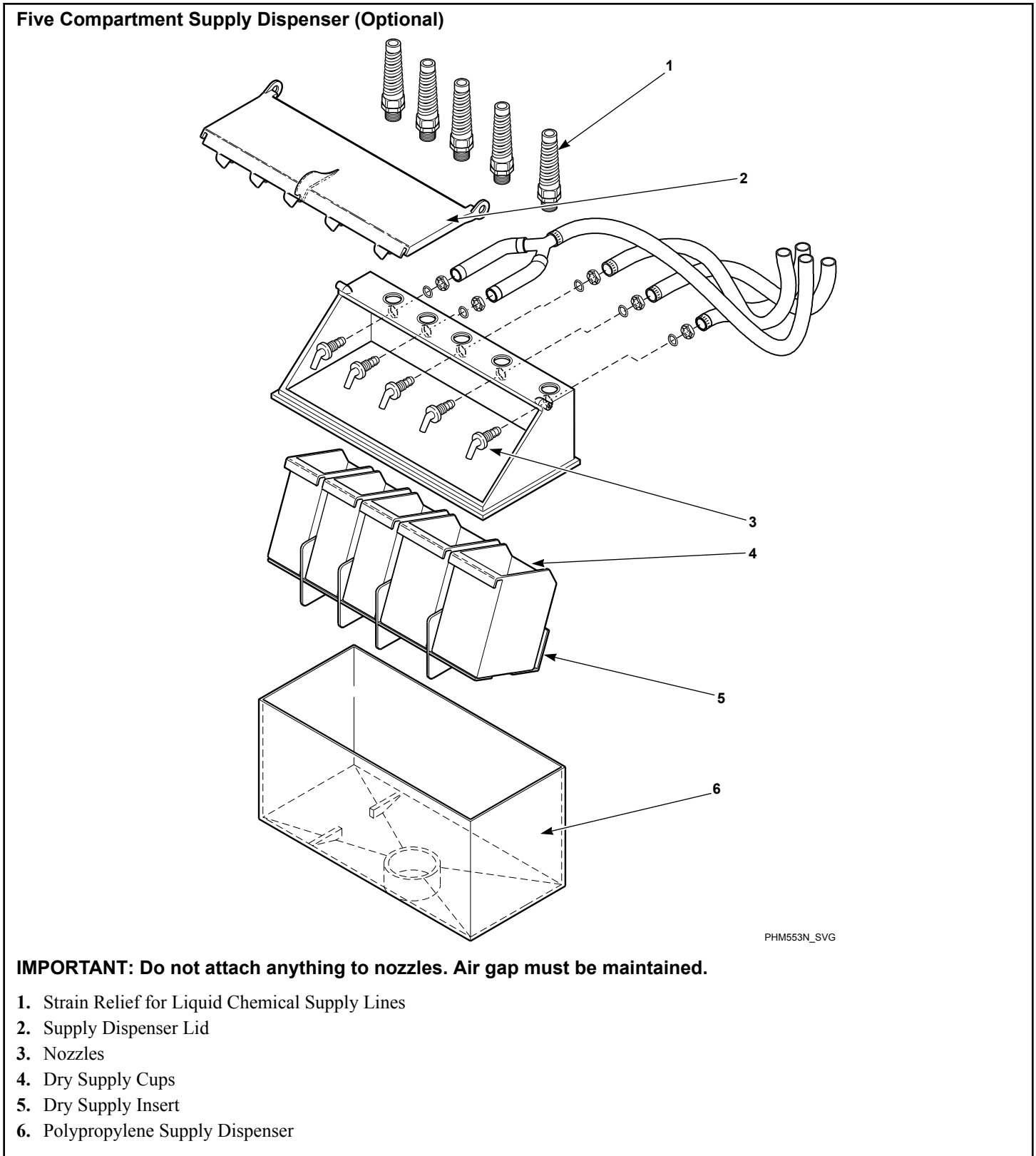

Figure 35

1. Remove knockout from supply dispenser. Refer to *Figure 35* . Plugs are assembled inside the tubing ring.
2. Install PG connector in hole with strain reliefs, included in the seal nut.
3. Insert tubes through PG base. Do not remove cups. Tube should extend into the plastic cup, with the exception of the softener tube, which should be routed to the outside of the cup.
4. Tighten the seal nut to prevent tubing from escaping the assembly.
5. Before operating machine, confirm lid is completely closed.

Do not attempt to make chemical injection electrical connections to points other than those provided specifically for that purpose by the factory.

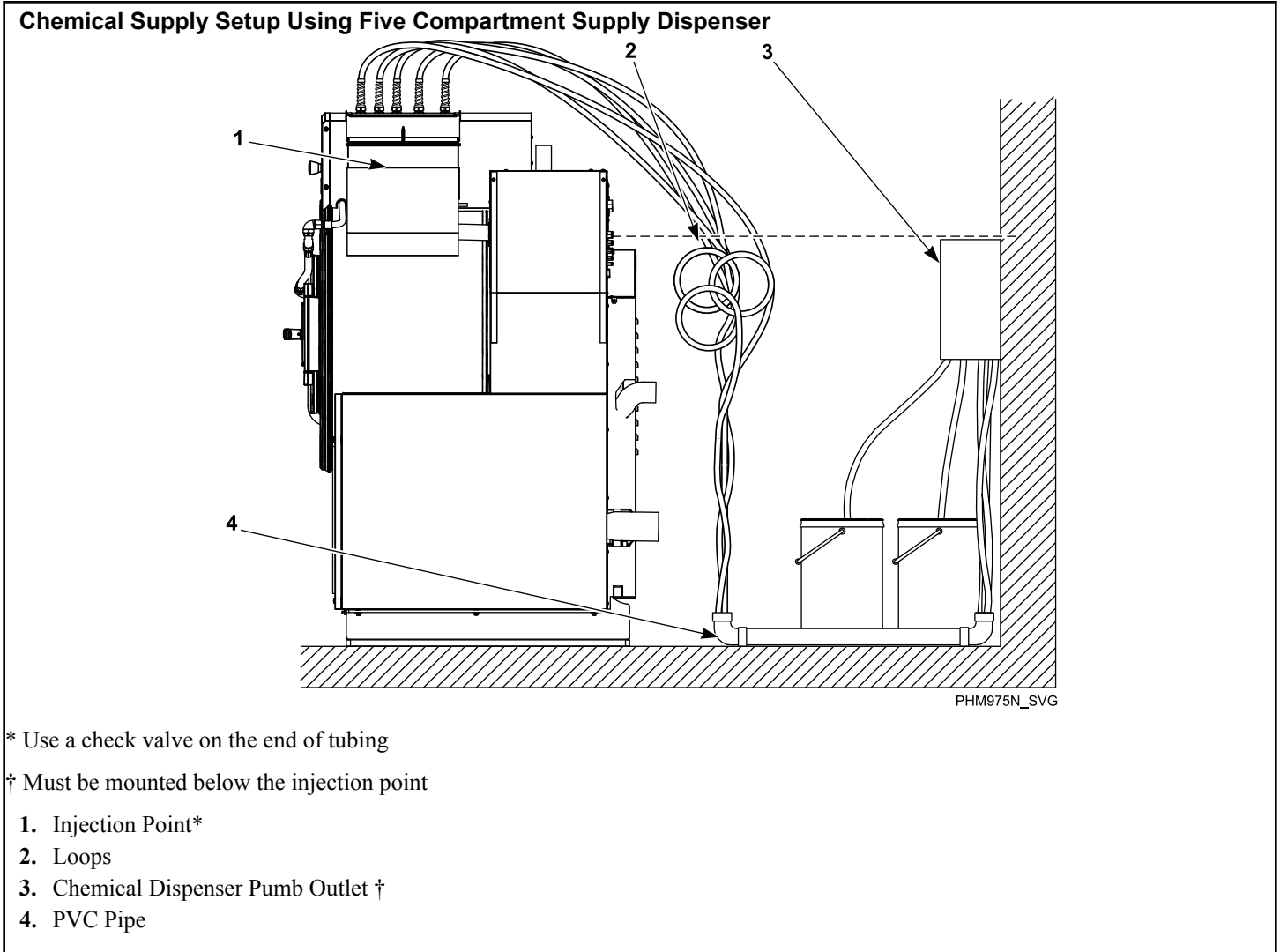

Figure 36

## External Supplies

For proper communication between the machine and an external chemical supply system, it is important for the low-voltage signal power to be connected properly. The included wiring diagram shows several different options for safe and correct wiring of this interface.

The preferred method for connecting the wiring from the external chemical supply system to the machine is to use the 300mA power of the machine's 24VAC control transformer, which is intended strictly for this purpose. Refer to *Figure 37* and *Figure 38* . Other

voltage and current options are available, but require some wiring changes and must be provided with an external power source. Under no circumstances should the high-voltage machine supply connections or source be used for the communication wiring.

Communication wiring connections, which is H2 a single row green connector on a small output board and H4 a single row green connector on the large output board, can be found under a service panel at the upper back of the machine.

### Chemical Injection Using Internal 24VAC Control Transformer

**NOTE:** Using the Internal 24VAC 300 Milliamp Control Transformer is recommended by Alliance Laundry Systems.



CAUTION

**Do not attempt to increase fuse rating or alter wiring of external chemical supply terminal strip in such as way that may conflict with the suggested methods provided on the Optional External Supply Wiring Diagram.**

W699

**IMPORTANT:** Do not use the transformer terminals if an external power supply is used.

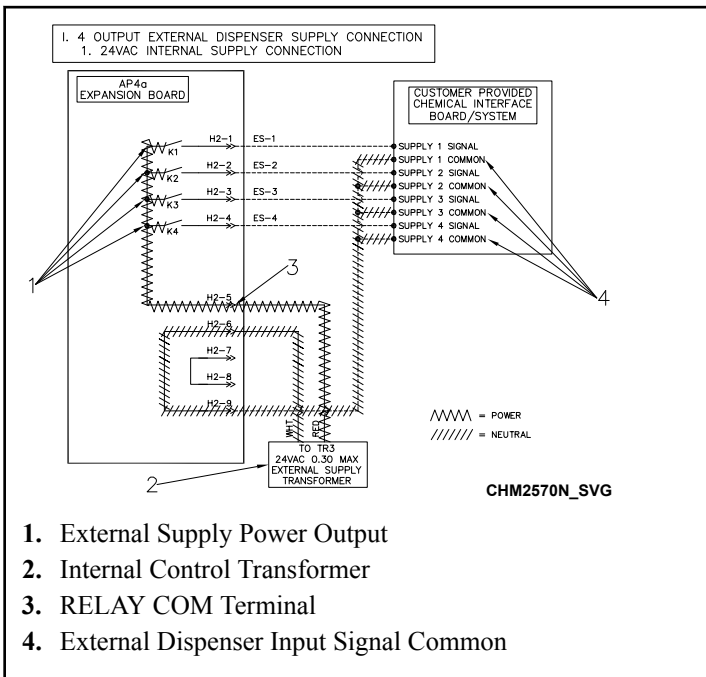
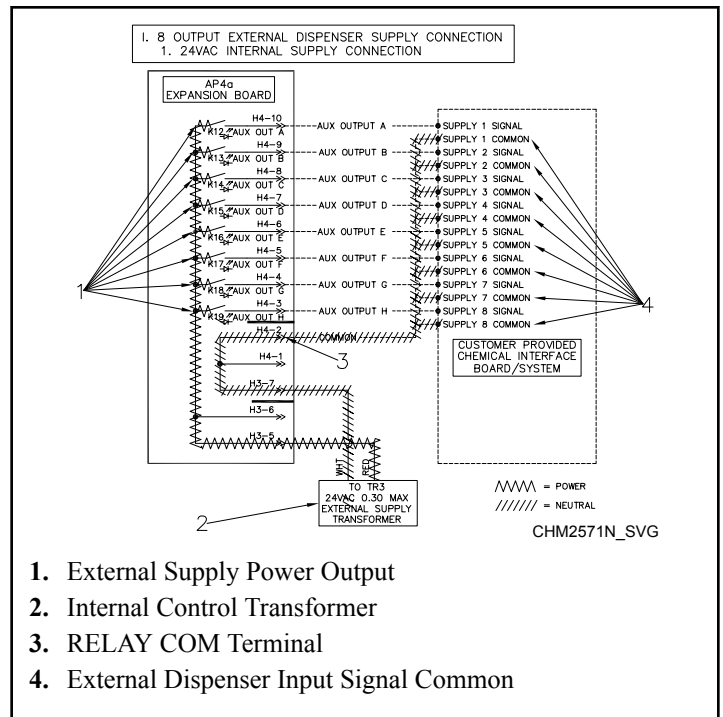

Figure 37



1. External Supply Power Output
2. Internal Control Transformer
3. RELAY COM Terminal
4. External Dispenser Input Signal Common

Figure 38

### Chemical Injection Using External AC Power Source

**NOTE:** An External AC Power Source is NOT provided by Alliance Laundry Systems.

**NOTE:** Power for external supplies must not be derived from the high-voltage main power connection point.

**IMPORTANT:** The external power must supply power of 240VAC or less and be protected at 3 Amps or less.

1. Disconnect and cap off the Red and White 24VAC wires.
2. Connect one side of the external power to the “RELAY COM” and the other to the external dispenser input signals common. Refer to *Figure 39* and *Figure 40*.

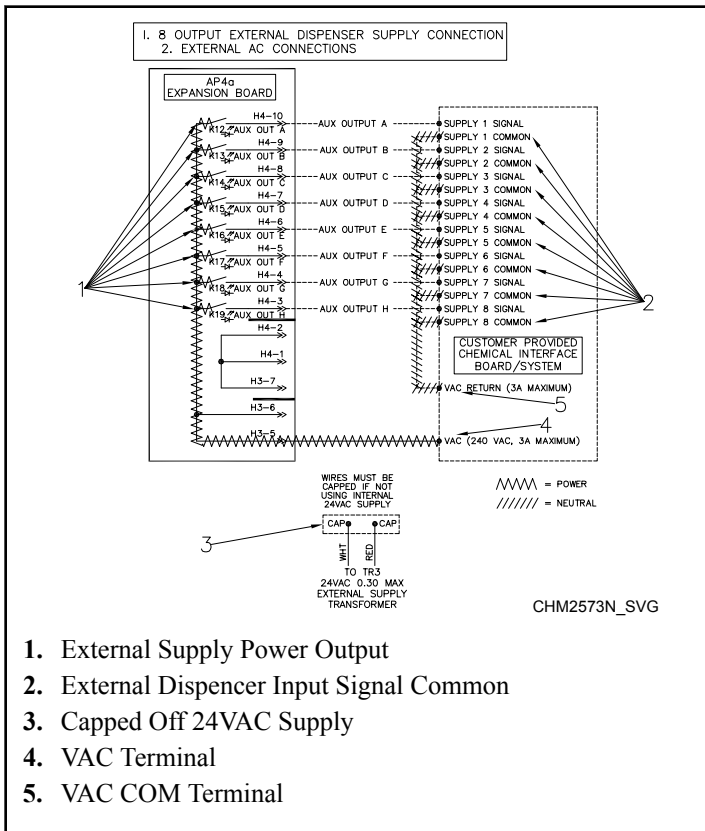
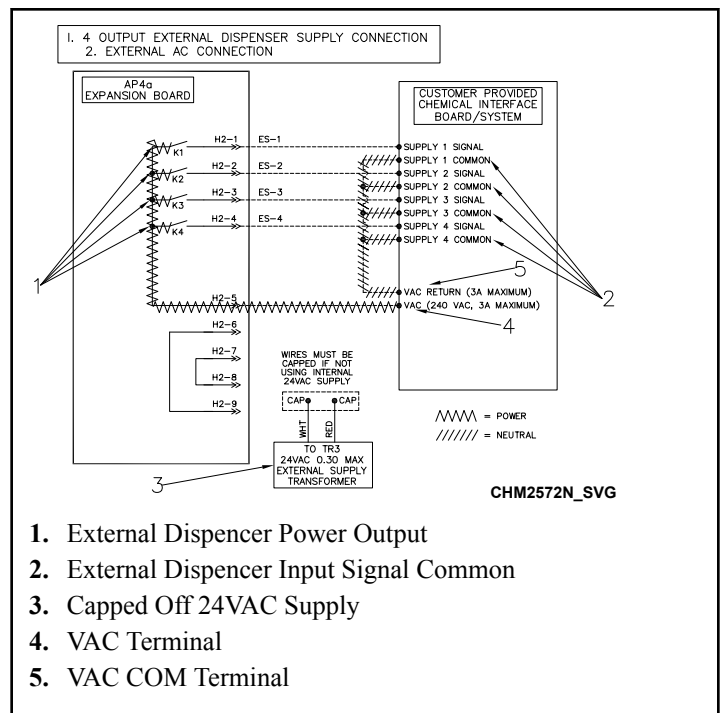

Figure 39



1. External Dispenser Power Output
2. External Dispenser Input Signal Common
3. Capped Off 24VAC Supply
4. VAC Terminal
5. VAC COM Terminal

Figure 40



### CAUTION

**Do not attempt to increase fuse rating or alter wiring of external chemical supply terminal strip in such as way that may conflict with the suggested methods provided on the Optional External Supply Wiring Diagram.**

W699

### External Supply Signals

Wash-cycle signals are provided to the external chemical supply equipment and a “wait for the next step” signal can be received from the supply equipment.

For example of a 4-signal board, if ES1 is selected the K1 contact will close and power will be supplied to Supply 1 Signal. The contact will remain closed for the amount of time programmed in control. Refer to *Figure 41* for Internal Supply Connection or *Figure 43* for External AC Connection.

For example of an 8-signal board, if ES1 is selected the K12 contact will close and power will be supplied to Supply 1 Signal. The contact will remain closed for the amount of time programmed in control. Refer to *Figure 42* for Internal Supply Connection or and *Figure 44* for External AC Connection.

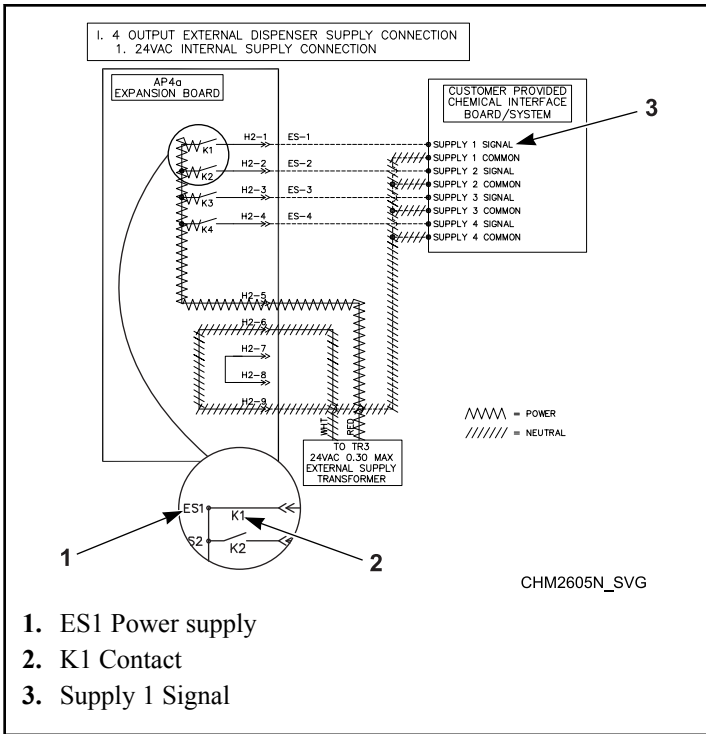

Figure 41

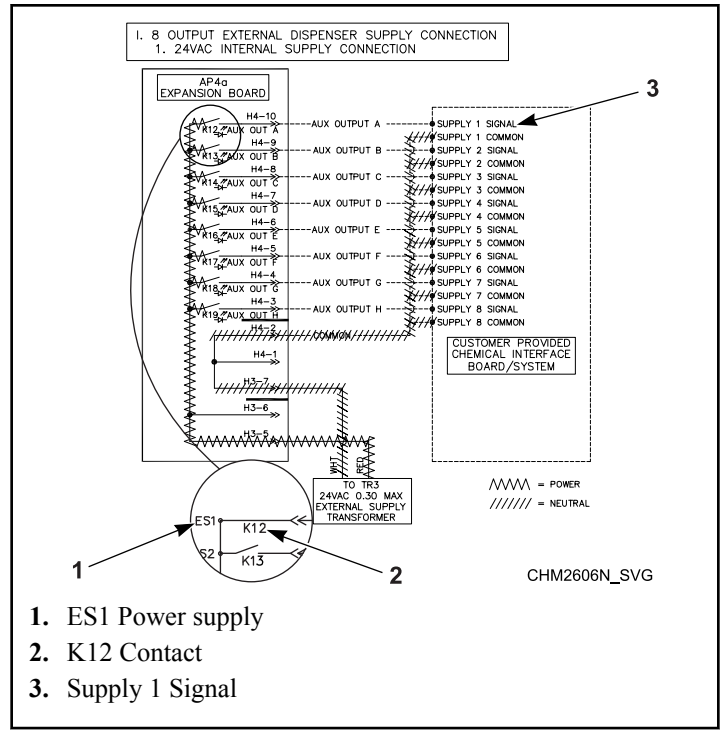

Figure 43

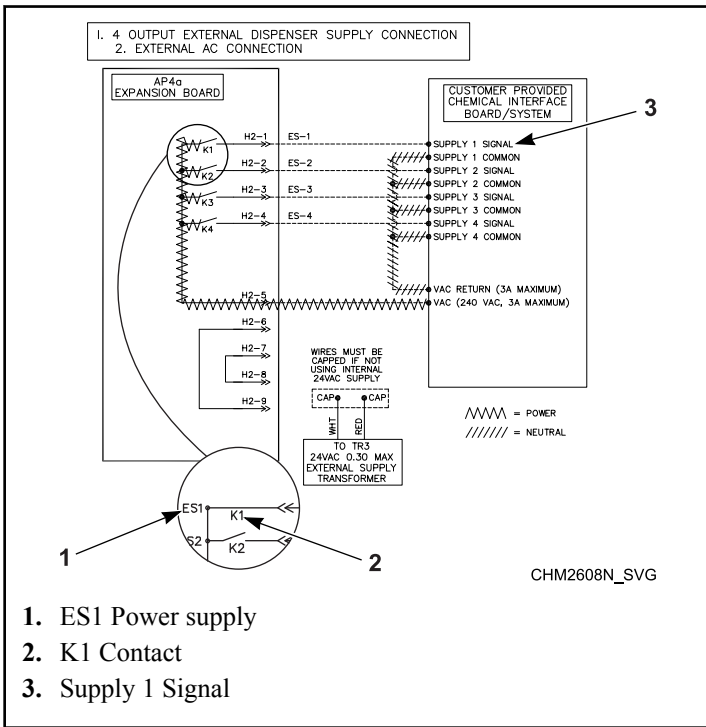

Figure 42

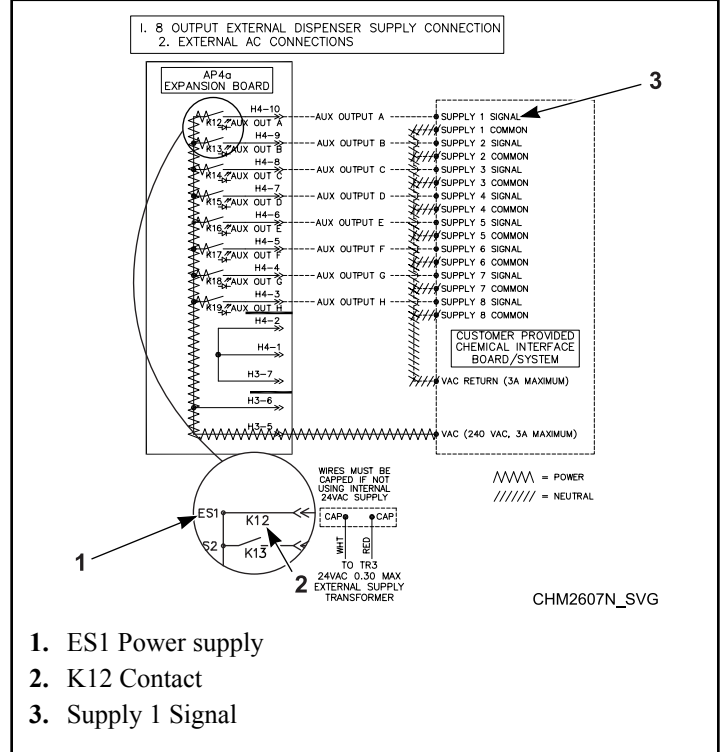

Figure 44

# Start Up

## Basket Rotation

After installation is complete, run the machine through a test cycle and check that basket rotation is counter clockwise in the extract step.

1. If rotation is not counter clockwise, disconnect power to machine.
2. Have a qualified electrician reverse any two motor leads at the motor.

## Safety Stability Switch Operation

After machine is properly installed, the safety Stability Switch operation must be verified.

1. Locate the green-colored switch on the rear, left-side of the frame.
2. Place a large magnet above the normally-closed ball switch to verify switch operation.

**IMPORTANT: Machines are manufactured with a normally-closed ball switch and should not require any adjustment. To avoid nuisance tripping, machine must be level with a summed value of 3/8 inch (9.5 mm) front to back and right to left to the earth. If switch is tripped, check if machine is level and then for poor grouting and broken anchor bolts. DO NOT BYPASS SAFETY SWITCH. Contact a qualified service technician for further assistance.**

# Operation

## Operating Instructions

1. Turn on main power source (circuit breaker).
2. Turn handle clockwise to open. Refer to *Figure 45*.

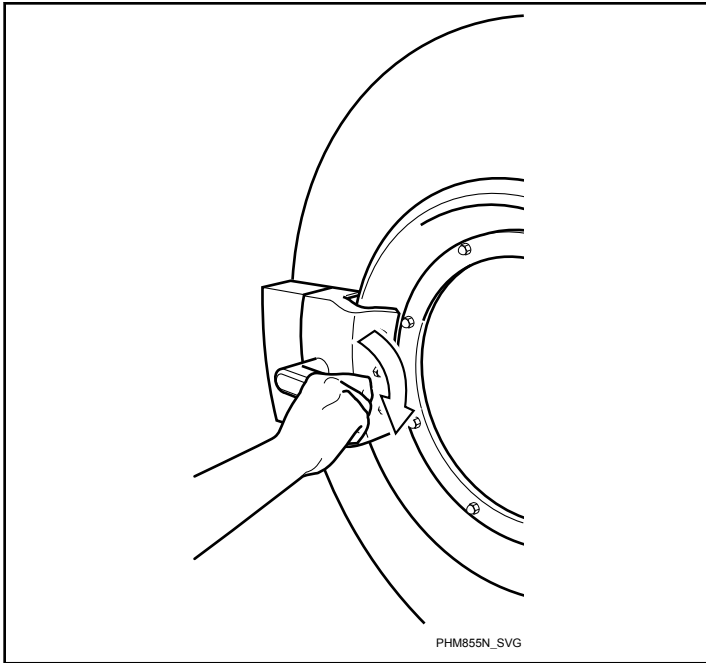



Figure 45

3. Load to capacity whenever possible. **DO NOT OVERLOAD.** Refer to *Figure 46*.

**NOTE: Underloading can cause out-of-balance conditions that can shorten machine life.**

	<h3>CAUTION</h3>
<p>Be careful around the open door, particularly when loading from a level below the door. Impact with door edges can cause personal injury.</p>	
<p>SW025</p>	

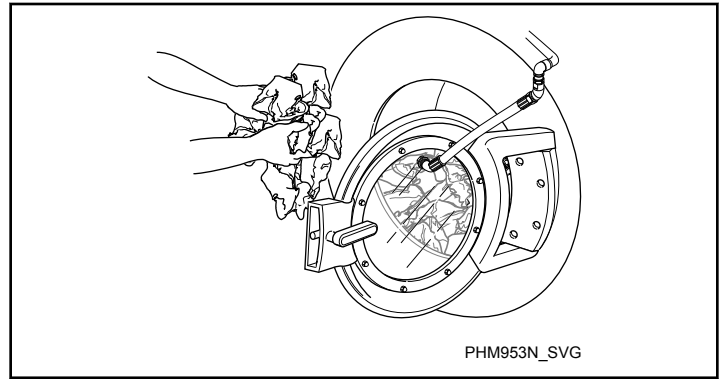

Figure 46

**NOTE: When washing items which may disintegrate or fragment, such as mop heads or sponges, use laundry nets to prevent drain blockage.**

**IMPORTANT: To prevent out-of-balance conditions, premature wear or damage to machine when using laundry nets, use several small nets in a load.**

4. Close the door and turn handle counter clockwise. Refer to *Figure 47*.

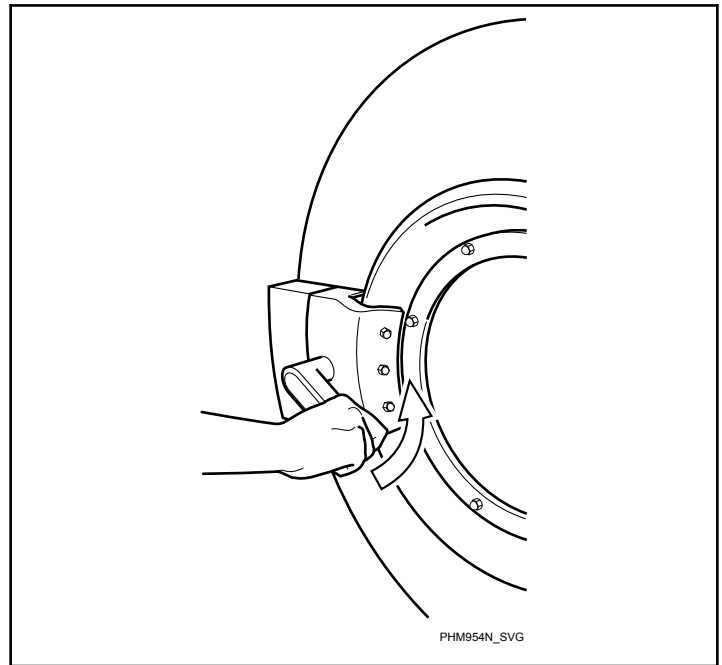



Figure 47

5. Refer to *OPL Control Instructions* to select and start a cycle.



	<h2 style="text-align: center;">CAUTION</h2>
<p>Water cannot be extracted from rubber backed items. To avoid damage to machine from out of balance conditions, do not use a spin (extract) step when washing rubber backed items. Warranty will be voided.</p> <p style="text-align: right;">W880</p>	

	<h2 style="text-align: center;">WARNING</h2>
<p>To prevent personal injury, avoid contact with inlet water temperatures higher than 125° Fahrenheit [51° Celsius] and hot surfaces.</p> <p style="text-align: right;">W748</p>	

## Control Instructions

**NOTE:** The control digit is the 7th digit in the model number. Example: UWT045[D]30VQ050LA00

### Models with N Control

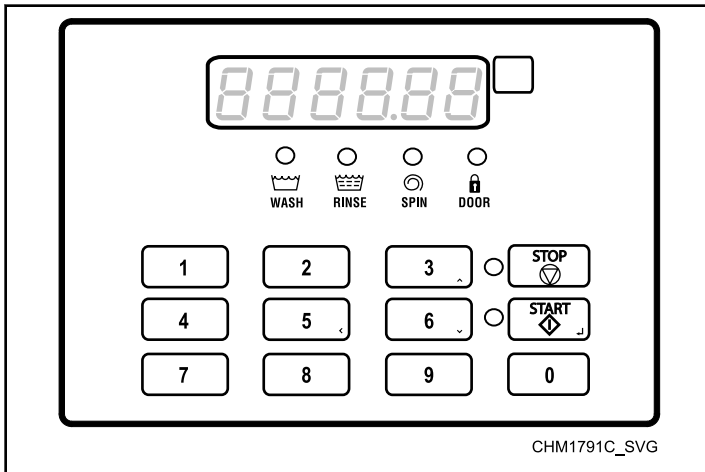

Figure 48

1. If equipped with an optional supply dispenser, add dry supplies to the compartment cups prior to the start of each cycle. Liquid supplies can be injected directly into the supply dispenser by an external chemical supply system.

**NOTE: Supply dispenser compartment cups must not be removed when an external chemical injection supply system is attached to the machine.**

2. Press the 1, 2, 3, 4, 5, 6, 7, 8, 9 or 0 keypad to select the desired cycle.
3. Press the START (enter) keypad to select.

**NOTE: Cycles cannot be changed anytime after the machine is started.**

4. When a cycle is complete, the control displays *OPEN DOOR*.

### Models with D Control

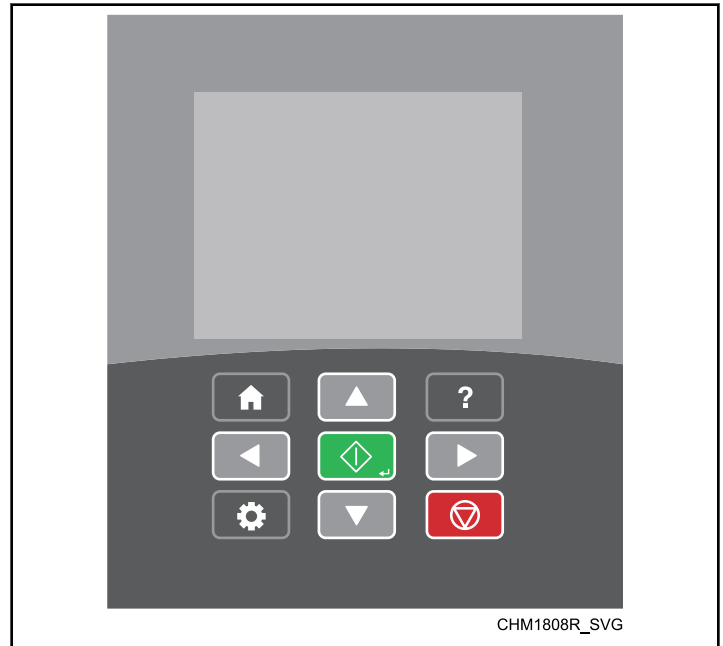

Figure 49

1. If equipped with an optional supply dispenser, add dry supplies to the compartment cups prior to the start of each cycle. Liquid supplies can be injected directly into the supply dispenser by an external chemical supply system.

**NOTE: Supply dispenser compartment cups must not be removed when an external chemical injection supply system is attached to the machine.**

2. If display has gone blank due to sitting idle, press the home keypad.
3. Press the ▲ or ▼ keypad to scroll through the cycle list.

**NOTE: Refer to the Programming Manual to customize a cycle.**

4. Press the ◊ keypad to start the highlighted cycle.

**NOTE: Refer to the Programming Manual to Rapid Advance a cycle.**

5. When a cycle is complete, the control displays "Cycle Complete".

## Emergency Stop Button

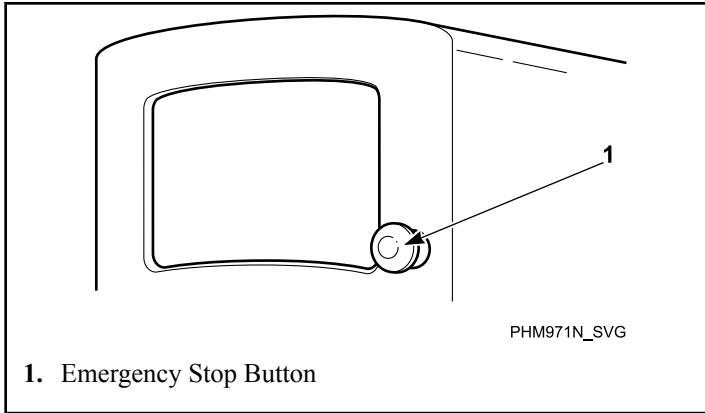

1. Emergency Stop Button

Figure 50

1. Press red emergency stop button to stop all action.
2. To restart the machine, pull red emergency stop button out and press START (enter) on the control.

## Shakeout Routine

	WARNING
<p><b>NEVER</b> insert hands or objects into basket until it has completely stopped. Doing so could result in serious injury.</p>	
SW012	

A Shakeout agitation step is programmed at the end of every cycle and will help prevent tangling of the load.

The Shakeout time is set at the factory to agitate for 40 seconds. Refer to **Programming Manual** to disable or change the time of the Shakeout.

## Basket Jog Feature (160 and 200 Pound Models Only)

With the door open and the control in Cycle Menu, press and HOLD both jog buttons with both hands. A series of loud beeps will occur, indicating the jog feature is about to start.

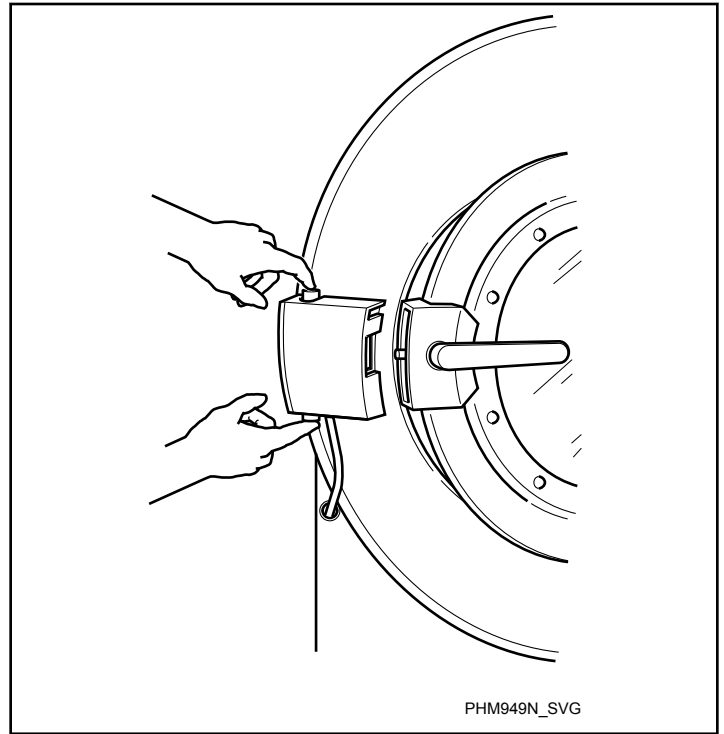



Figure 51

The jog feature is deactivated when the loading door is closed and the jog buttons are not pressed.

	WARNING
<p><b>To avoid personal injury, do NOT reach into the basket while it is rotating. Keep all personnel at a safe distance from the machine while using the Basket Jog Feature.</b></p>	
W641	

# Maintenance

Routine maintenance maximizes operating efficiency and minimizes downtime. The maintenance procedures described below will prolong the life of the machine and help prevent accidents.

	<b>WARNING</b>
<p><b>Sharp edges can cause personal injury. Wear safety glasses and gloves, use proper tools and provide lighting when handling sheet metal parts.</b></p>	
W366R1	

	<b>CAUTION</b>
<p><b>Replace all panels that are removed to perform service and maintenance procedures. Do not operate the machine with missing guards or with broken or missing parts. Do not bypass any safety devices.</b></p>	
SW019	

Follow local codes for proper advise on laundering infected garments.

The following maintenance procedures must be performed regularly at the required intervals.

## Daily

**IMPORTANT: Replace all panels that are removed to perform maintenance procedures. Do not operate the machine with missing guards or with broken or missing parts. Do not bypass any safety devices.**

	<b>WARNING</b>
<p><b>Do not spray the machine with water. Short circuiting and serious damage may result.</b></p>	
unique_69_Connect_42_note-1437506691659	

**IMPORTANT: Door lock should be checked daily to ensure proper operation. Also check that all safety and instruction stickers are on the machine. Any missing or illegible safety instructions stickers should be replaced immediately.**

## Beginning of Day

1. Inspect the door interlock before starting operation.
  - a. Attempt to start the machine with the door open. The machine should not start.
  - b. Close the door without locking it and start the machine. The machine should not start.
  - c. Attempt to open the door while the cycle is in progress. The door should not open.

If the door lock and interlock are not functioning properly, disconnect power and call a service technician.

2. Inspect the water inlet valve hose connections on the back of the machine for leaks.
3. Inspect the chemical connections for machines equipped with an automatic chemical supply system by inspecting all connections and chemical hoses for leaks or cracks.
4. If applicable, inspect the steam hose connections for leaks.
5. If the machine is equipped with a premium Wet Clean module, inspect the water recirculation pipe connections to make sure that they are tight and do not leak.
6. Ensure all panels and guards are properly installed.

## End of Day

1. Clean the wash drum, door glass, and door gasket of residual detergent and all foreign matter.
2. Clean the chemical dispenser, flushing with clean water.
3. Clean the machine's exposed surfaces with all-purpose cleaner.

**IMPORTANT: Use only isopropyl alcohol to clean graphic overlays. DO NOT use ammonia based or vinegar-based cleans on overlays.**

**NOTE: Unload the machine promptly after each completed cycle to prevent moisture buildup. Leave loading door and dispenser lid open at the end of each completed cycle to allow moisture to evaporate.**

4. If applicable, clean the AC invert drive filter.
  - a. Remove the external plastic cover which contains the filter.
  - b. Remove the foam filter from the cover.
  - c. Wash the filter with warm water and allow to air dry. Filter can be vacuumed clean.

**NOTE: The control module and drive box cover and fan filter must be in place for the fan to properly cool the AC inverter drive and front end control. Failure to observe this warning will void the warranty and could lead to expensive AC inverter drive repair or front end control replacement.**

5. Leave the loading door and dispenser lid open to allow moisture to evaporate.

**NOTE: Unload the machine promptly after each completed cycle to prevent moisture buildup.**

6. Shut off water supply.

## Monthly

**NOTE: Disconnect power to the machine at its source before performing the monthly maintenance procedures.**

1. Inspect the electrical connections for looseness. Tighten as required after disconnecting power.
  - a. Verify that insulation is intact on all external wires and that all connections are secure. If bare wire is evident, call a service technician.
2. Clean inlet hose filter screens.
  - a. Turn water off and allow valve and water line to cool, if necessary.
  - b. Unscrew inlet hose from the faucet and remove filter screen.
  - c. Clean with soapy water and reinstall. Replace if worn or damaged.
  - d. Repeat procedure with the filter located inside the valve at the back of the machine.

**NOTE: All filter screens should be replaced every five years.**

3. If applicable, clean the customer-supplied steam filter. Refer to *Figure 52*.
  - a. Turn off steam supply and allow time for the valve to cool.
  - b. Unscrew cap.
  - c. Remove element and clean.
  - d. Replace element and cap.

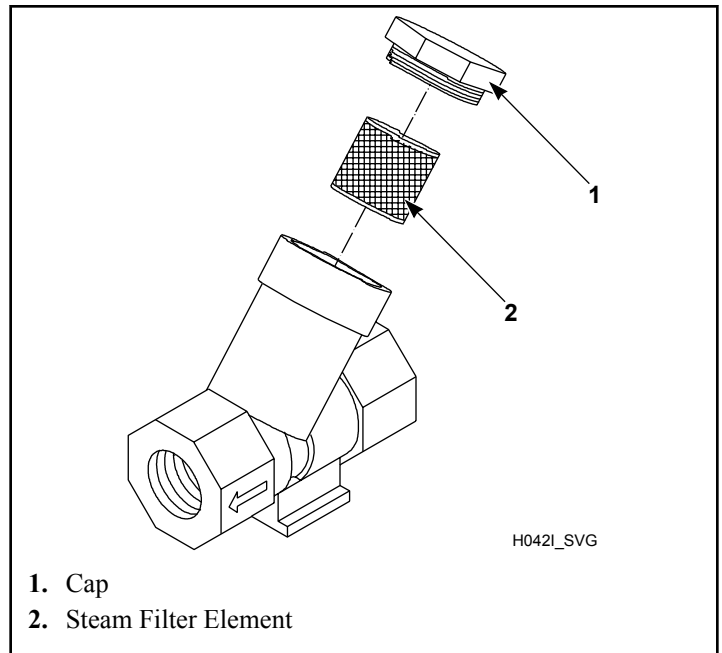

Figure 52

4. For electric heat models only, inspect heating elements for excess debris by rotating basket to view them through its perforations. Remove drain valve hose to access and clear debris with pliers. Replace element(s) if necessary.

**NOTE: Lint buildup may take several months to occur. Inspect heating elements a minimum of every 6 months.**

- Lubricate the barings each month or after every 200 hours of operation. Visually inspect grease line for air pockets, purging air pockets as necessary.

The grease must have the following characteristics:

- NLGI Grade 2
- Lithium-based
- Water-insoluble
- Anti-rusting
- Anti-oxidizing
- Mechanically stable

The grease must have adequate base oil viscosity with one of the following ratings:

- ISO VG 150 (709–871 SUS at 100°F [135–165 cSt at 40°C])
- ISO VG 220 (1047–1283 SUS at 100°F [198–242 cSt at 40°C])
- An SAE 40 rating is also acceptable as long as the cSt or SUS values are within the specified ranges.

Pump the grease gun slowly, permitting only 2 strokes.

**NOTE: Do not pump the grease gun until grease comes out of the bearing housing. This can result in over lubrication, causing damage to bearings and seals.**

## Yearly

**NOTE: Disconnect power to the machine at its source before performing maintenance procedures.**

- Remove the front panel(s) and rear access panels and inspect all hose, drain, and overflow connections/clamps for leaks. Inspect all hoses for visible signs of deterioration. Replace as necessary.
- Inspect the belt for unusual wear, frayed edges, and improper belt tension, replacing belts and/or adjusting tensioning elements as necessary.

**NOTE: Belts must not be twisted and must be properly seated on pulleys. Belt must be centered on basket pulley within .04 inches [1 mm].**

- Use the following procedures to determine if belt(s) require replacement or adjustment. Call a qualified service technician in either case.

**NOTE: Basket pulley must be rotated three (3) full turns before assessing belt tension after every adjustment.**

- Frequency Gauge.** Tighten eyebolt top nut until the correct frequency (refer to *Table 6*) is obtained mid-span. Torque jam nut to spring bracket to  $20.6 \pm 2$  ft.-lbs. Refer to *Figure 53*.

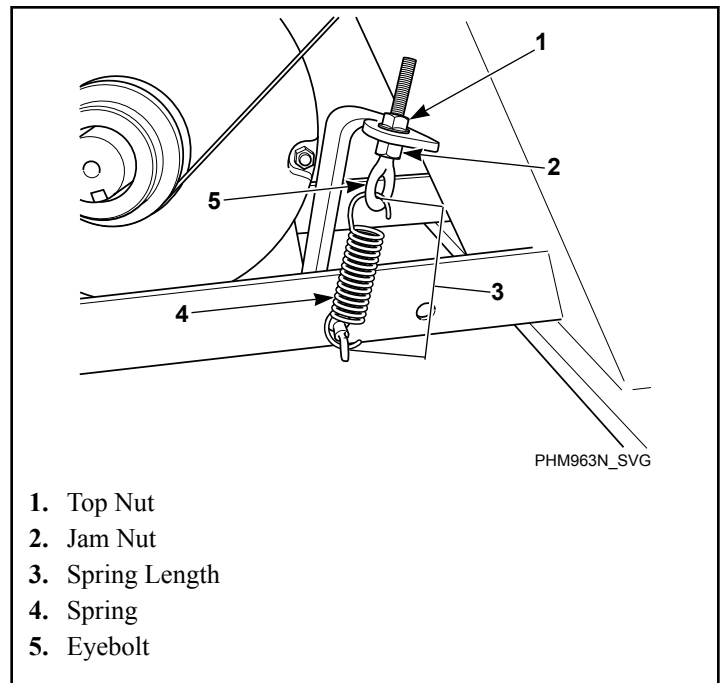

- Top Nut
- Jam Nut
- Spring Length
- Spring
- Eyebolt

Figure 53

- Tension Gauge.** Tighten eyebolt top nut until the proper belt gauge (refer to *Table 6*) is obtained mid-span. Torque jam nut to spring bracket to  $20.6 \pm 2$  ft.-lbs. Refer to *Figure 53*.
- Spring Length.** Tighten eyebolt top nut until the spring measures the correct distance between the hooks. Refer to *Table 42*. Torque jam nut to spring bracket to  $20.6 \pm 2$  ft.-lbs. Refer to *Figure 53*.

Spring Length, in. [mm]	
Model	Distance Between Hooks
45-65	4-1/16 [103]
85-105	5-7/16 [139]
130-160	5-7/8 [149]
200	6-7/16 [165]

Table 42

- Maintain Tension During Belt Removal.** If proper tension is achieved, tape the jam nut in place and loosen eyebolt top nut to release the belt. Replace belt and retighten eyebolt top nut back to jam nut position. Refer to *Figure 53*.

**IMPORTANT: All torque joints must remain dry (non-lubricated).**

- Verify that belt is properly aligned by checking pulley alignment. On 45-105 pound models, the motor pulley should align with end of motor shaft to align belts. On

130-160 pound models, slide the motor pulley along the motor shaft and secure once belt alignment on the sheave is attained.

1. Install belt on basket sheave.
2. Install belt on motor pulley.
3. Insert belt in appropriate motor pulley grooves so belt rides on the center of the basket sheave. Belt must be centered on basket pulley within .04 inch [1 mm].

<b>Belt Tension by Frequency or Belt Tension Gauge</b>			
<b>Model</b>	<b>Frequen- cy (Hz)</b>	<b>Belt Ten- sion (lbs.)</b>	<b>Tension Gauge (N)</b>
45-65	58 ± 2	108 ± 7	481 ± 32
85-105	62 ± 2	183 ± 11	816 ± 52
130-160	52 ± 1	214 ± 16	954 ± 72
200	61 ± 1	300 ± 16	1335 ± 72

Table 43

10. Run factory test, reference programming manual for procedure details and components tested.

**NOTE: Refer to the Programming Manual for procedure details and components tested.**

11. Inspect all painted surfaces for exposed metal. Replace or repaint if necessary.
  - If bare metal is showing, paint with primer or solvent-based paint.
  - If rust appears, remove it with sandpaper or by chemical means. Repaint with primer or solvent-based paint.

12. Torque anchor bolts and inspect grout for cracking.

**NOTE: Refer to the Installation Manual for anchor bolt specifications.**

**IMPORTANT: All torque joints must remain dry (non-lubricated).**

13. Every 5 years replace inlet hoses, hose screens, belt, and fan filter (if applicable).

3. Remove any accumulated debris on or near the motor and motor variable frequency drive heat sinks, if applicable.
4. If applicable, unlock or unscrew the top cover and inspect the supply dispenser hoses and hose connections for visible signs of deterioration. Replace hoses if worn or damaged.

**NOTE: Hoses and other natural rubber parts deteriorate after extended use. Hoses may develop cracks, blisters or material wear from the temperature and constant high pressure they are subjected to.**

5. Remove any dust from all electrical components, including coin acceptors if applicable, with compressed air.
6. Inspect hardware for any loose nuts, bolts, screws.
  - a. Check the tightness of the motor spring and motor pulley hardware. Also check that the eyebolt is tightened properly.
  - b. Tighten motor mounting bolt locknuts and bearing bolt locknuts, if necessary.
  - c. Check the bearing mounting bolts to make sure they are torqued properly. Torque value should be 357 ± 35 ft-lbs.
  - d. Tighten door hinges and fasteners, if necessary.
7. Place a large magnet over the normally-closed ball switch to verify the stability switch operation.
8. From the rear of the machine, locate the air trap hose through the hole in the frame. Remove and check for debris.
9. Ensure all panels and guards are properly reinstalled.
  - a. Verify that the drain motor shield is in place and secure, if so equipped.

## Care of Stainless Steel

- Remove dirt and grease with detergent and water. Thoroughly rinse and dry after washing.
- Avoid contact with dissimilar metals to prevent galvanic corrosion when salty or acidic solutions are present.
- Do not allow salty or acidic solutions to evaporate and dry on stainless steel. Wipe clean of any residues.
- Rub in the direction of the polish lines or “grain” of the stainless steel to avoid scratch marks when using abrasive cleaners. Use stainless steel wool or soft, non-metal bristle brushes. Do not use ordinary steel wool or steel brushes.
- If the stainless steel appears to be rusting, the source of the rust may be an iron or steel part not made of stainless steel, such as a nail or screw.
- Remove discoloration or heat tint from overheating by scouring with a powder or by employing special chemical solutions.
- Do not leave sterilizing solutions on stainless steel equipment for prolonged periods of time.
- When an external chemical supply is used, ensure no siphoning of chemicals occurs when the machine is not in use. Highly concentrated chemicals can cause severe damage to stainless steel and other components within the machine. Damage of this kind is not covered by the manufacturer’s warranty. Locate the pump and tubing below the machine’s injection point to prevent siphoning of chemicals into the machine.



# Disposal of Unit

This appliance is marked according to the European directive 2002/96/EC on Waste Electrical and Electronic Equipment (WEEE).

This symbol on the product or on its packaging indicates that this product shall not be treated as household waste. Refer to *Figure 54*. Instead it shall be handed over to the applicable collection point for the recycling of electrical and electronic equipment. Ensuring this product is disposed of correctly will help prevent potential negative consequences for the environment and human health which could otherwise be caused by inappropriate waste handling of this product. The recycling of materials will help to conserve natural resources. For more detailed information about recycling of this product, please contact the local city office, household waste disposal service, or the source from which the product was purchased.

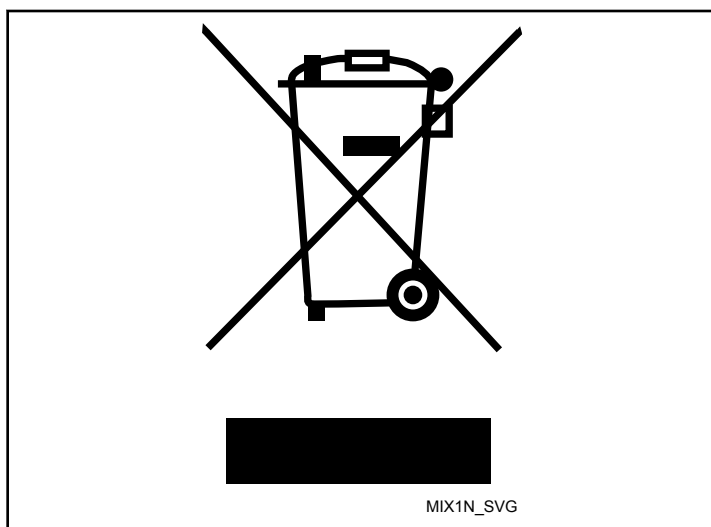

Figure 54

# China Restriction of hazardous substances (RoHS)

The Table of Hazardous Substances/Elements and their Content

As required by China's Management Methods for Restricted Use of Hazardous Substances in Electrical and Electronic Products

Hazardous substances						
Part Name	Lead (Pb)	Mercury (Hg)	Cadmium (Cd)	Hexavalent Chromium (CR[VI])	Polybrominated biphenyls (PBB)	Polybrominated diphenyl ethers (PBDE)
PCBs	X	O	O	O	O	O
Electromechanical Parts	O	O	O	O	O	O
Cables and Wires	O	O	O	O	O	O
Metal Parts	O	O	O	O	O	O
Plastic Parts	O	O	O	O	O	O
Batteries	O	O	O	O	O	O
Hoses and Tubing	O	O	O	O	O	O
Timing Belts	O	O	O	O	O	O
Insulation	O	O	O	O	O	O
Glass	O	O	O	O	O	O
Display	O	O	O	O	O	O

This table is prepared in accordance with the provisions of SJ/T-11364.

O: Indicates that the content of said hazardous substance in all of the homogenous materials in the component is within the limits required by GB/T 26572.

X: Indicates that the content of said hazardous substance exceeds the limits required by GB/T 26572 in at least one homogenous material in the component.

**All parts named in this table with an "X" are in compliance with the European Union's RoHS Legislation.**

**NOTE: The referenced Environmental Protection Use Period Marking was determined according to normal operating use conditions of the product such as temperature and humidity.**



This product under normal use, durable years of environmental protection is 15 years.